

Integra



*SlowMotion
Inside*



FORMENTI &
GIOVENZANA

Formenti & Giovenzana provides functional solutions for furniture to meet the real needs of a large number of customers.

All products are conceived and supplied with care and quality and are offered to the market at a competitive price.

In this way, Formenti & Giovenzana contributes globally to increase the satisfaction of the customers buying furniture, giving access to pleasing features and improving the quality of life of the consumers.



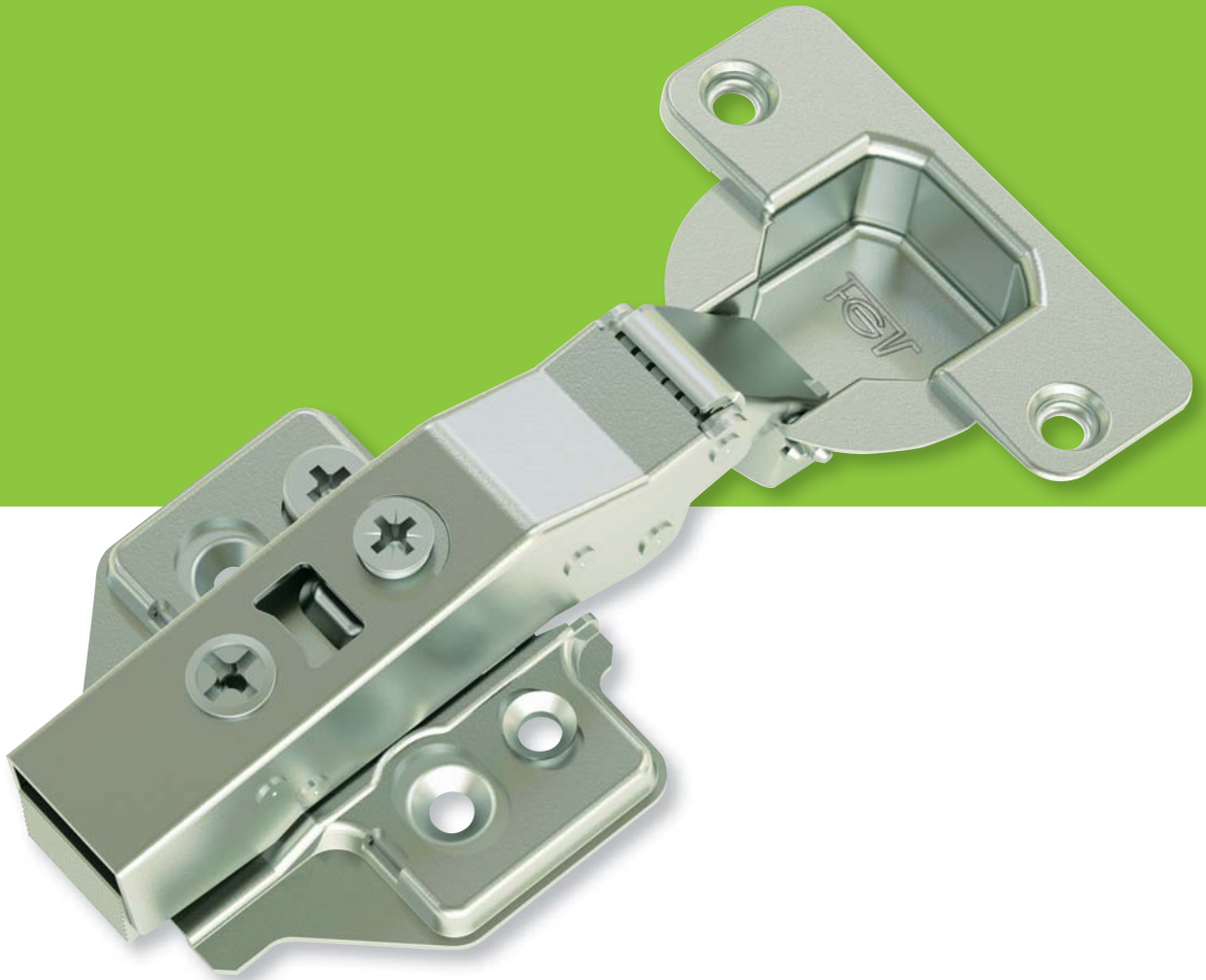

Integra

SlowMotion Inside

SlowMotion technology inside

Improved modern design

Strength and high performances

Easy click fixing system

The Integra hinge is the latest solution for dampening doors in the FGV range. A SlowMotion linear damper hidden in the hinge arm offers effective and constant performances under all conditions. A rapid installation and 3D adjustments allow to find easily the door's correct position. Integra is the right solution to meet the customer's needs keeping an eye on costs.

SlowMotion Inside

An hinge with a heart, a damper integrated into the arm, driving a controlled and silent movement. An advanced technology able to support strong and long lasting application. High stability and constant performances also under adverse closing conditions. A really accurate depth adjustment thanks to new spiral screw.



Modern design

Based on aesthetic and functionality combining design, the Integra hinge offers a practical use with a pleasant look. Moreover the soft door motion confers a further end-consumer appeal to the product.



Integra range

The Integra hinge program of cranks, angles and special solutions covers a complete range of applications and fits all the standard drilling patterns. Ensuring an optimal damping on various weights and sizes doors, Integra is perfectly suitable for different types of cabinets for kitchen, bathrooms, bedrooms, living room and all other solutions.



Technology background

Despite the apparent simplicity of the product, Integra is a cost-efficient collection of techniques, skills, methods and processes all put together. The result is a real affordable product with an high background of technology and safety.

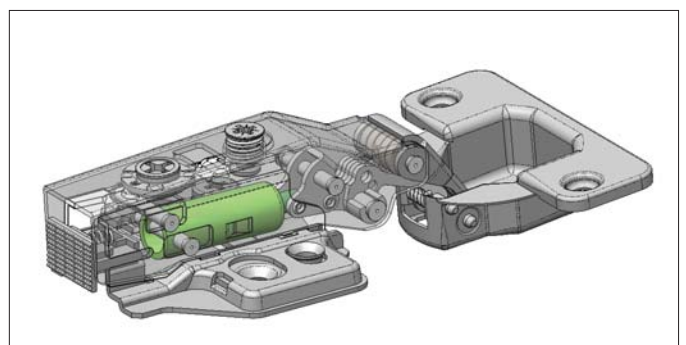
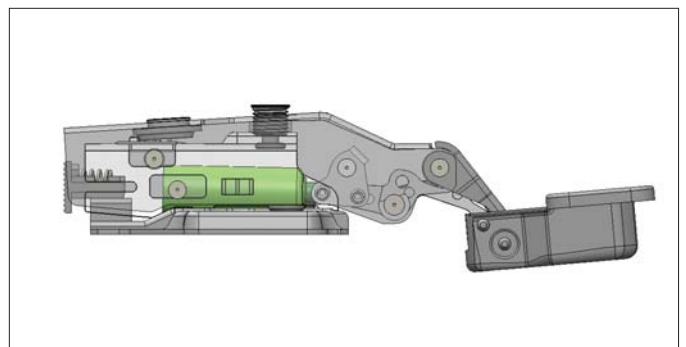

Integra

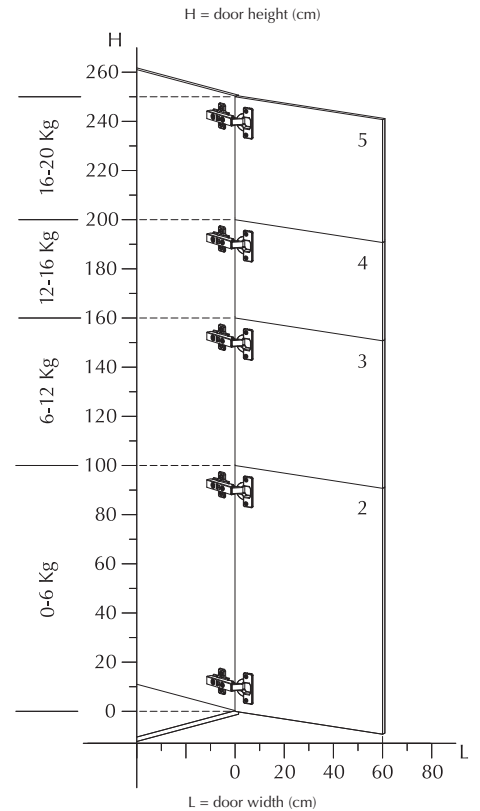
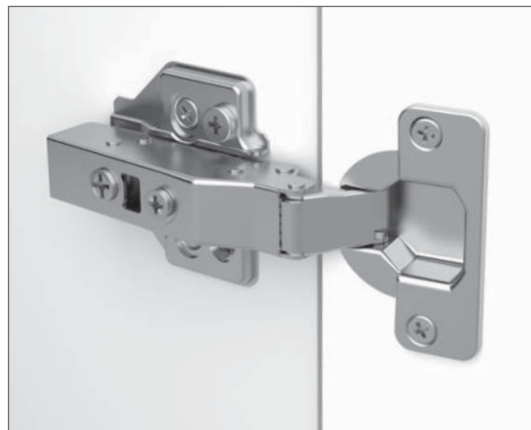

Mounting System

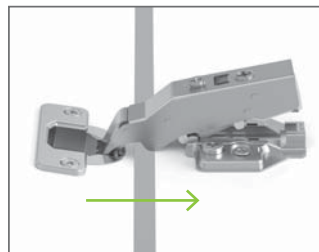

1 Place the front part of the hinge on the front side of the mounting plate.

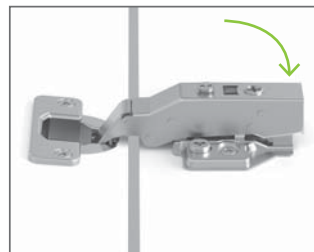

2 Rotate the arm of the hinge.



3 Press down the rear part of the hinge to Click on.

Adjusting System

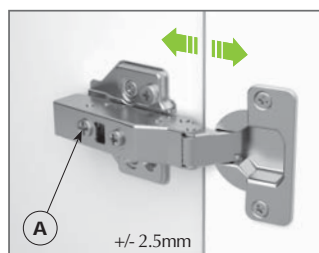

Depth adjustment
Acting on the "A" screw it is possible to adjust the distance between the side of the cabinet and the door.

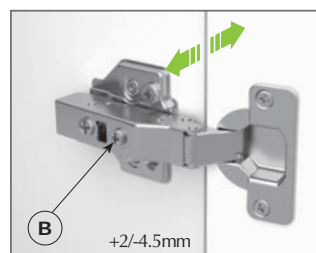

Independent side adjustment
Acting on the "B" screw it is possible to change the amount of the door covering on the side of the cabinet.

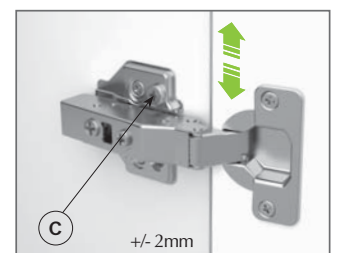

Vertical adjustment
Acting on the "C" screw of the mounting plate it is possible to adjust the door vertically.

INDEX

**OPENING
105°**



Product detail

p. 10-11

**OPENING
165°**



Product detail

p. 12-13

**FOR CORNER
DOORS
105°**



Product detail

p. 14-15

**FOR ALUMINIUM
FRAME
105°**



Product detail

p. 16-17

Integra 105°

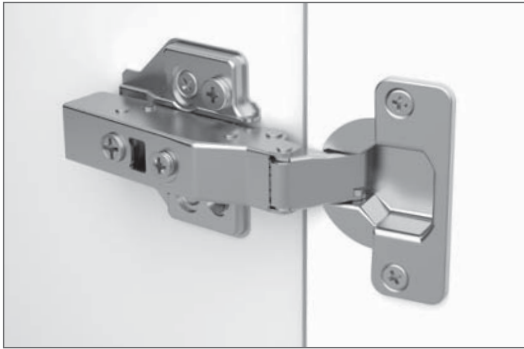

Technical specifications:

- Depth of the metal cup 11.3mm
- Cup diameter 35mm
- Opening 105° with (K) max 4mm and (T) max 18mm
- Possibility of door drilling (K) from 3 to 7 mm
- Thickness of the door (T) from 16 to 26 mm
- SlowMotion solution with linear damper

CRANK 0



CRANK 8



CRANK 15



I
A
D

51.BSH5.05.00.0
51.BSH5.05.00.C
51.BSH5.05.00.B

51.BSH5.05.08.0
51.BSH5.05.08.C
51.BSH5.05.08.B

51.BSH5.05.15.0
51.BSH5.05.15.C
51.BSH5.05.15.B



I
A
D

51.BSH6.05.00.M
51.BSH6.05.00.N
51.BSH6.05.00.E

51.BSH6.05.08.M
51.BSH6.05.08.N
51.BSH6.05.08.E

51.BSH6.05.15.M
51.BSH6.05.15.N
51.BSH6.05.15.E



I
A
D

51.BSH6.05.00.0
51.BSH6.05.00.S
51.BSH6.05.00.B

51.BSH6.05.08.0
51.BSH6.05.08.S
51.BSH6.05.08.B

51.BSH6.05.15.0
51.BSH6.05.15.S
51.BSH6.05.15.B

0, B = dowels Ø10mm / S = dowels Ø8mm



I
A
D

51.BSH8.05.00.V
51.BSH8.05.00.S
51.BSH8.05.00.Z

51.BSH8.05.08.V
51.BSH8.05.08.S
51.BSH8.05.08.Z

51.BSH8.05.15.V
51.BSH8.05.15.S
51.BSH8.05.15.Z

V, Z = dowels Ø10mm / S = dowels Ø8mm

Versions not damped (code 51.5SH5.05) available for all applications in the above table.

I

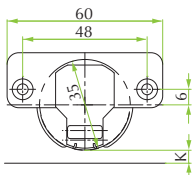

A

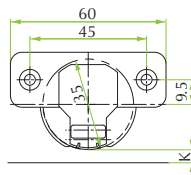

D

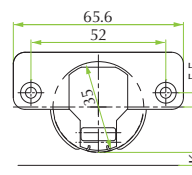

The mounting plates and fittings for this hinge series are shown from page 18 to page 20.

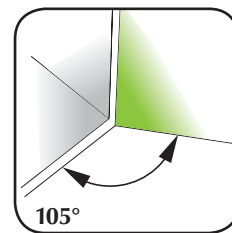
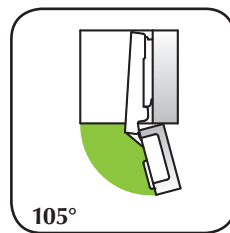

CRANK 0
For lay-on doors

CRANK 8
For partial lay-on doors

CRANK 15
For inset doors

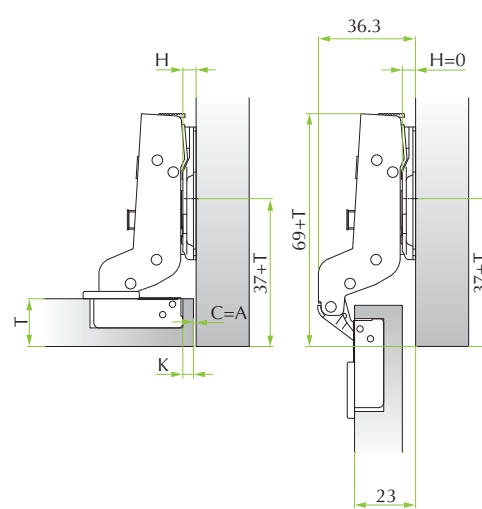
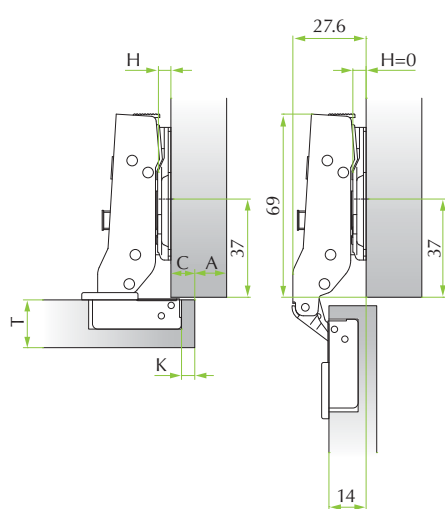
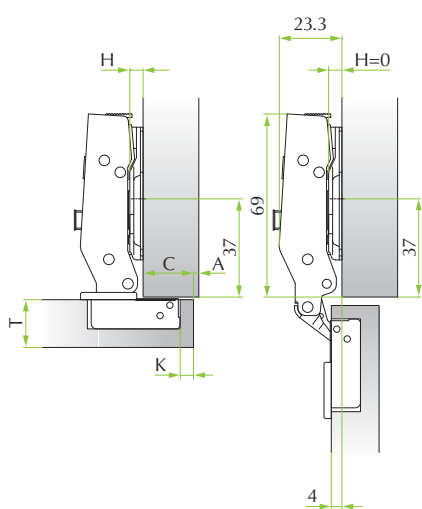

		Drilling distance (K)						
		3	4	5	6	7		
Overlay (C)	21					0		
	20				0			
	19			0	2			
	18		0	2				
	17	0	2	4				
	16	2	4					
	15	2	4					
	14	4						
13	4						Mounting plates (H)	

		Drilling distance (K)						
		3	4	5	6	7		
Overlay (C)	11					0		
	10				0			
	9			0	2			
	8		0	2				
	7	0	2	4				
	6	2	4					
	5	2	4					
	4	4						
3	4						Mounting plates (H)	

		Drilling distance (K)						
		3	4	5	6	7		
Overlay (C)	4	2						
	3		2					
	2	0		2				
	1		0		2			
	0			0		2		
								Mounting plates (H)

Table to determinate the minimum distance **A** so that a door with **T** thickness can open without protrusion from the cabinet and without interfering with adjacent doors.

	T=	16	17	18	19	20	21	22	23	24	25	26
K=3	A=	0.9	1.1	1.5	1.8	2.3	2.8	3.6	4.3	5.2	6.0	6.9
K=4	A=	0.8	1.1	1.4	1.8	2.2	2.7	3.3	4.0	4.7	5.5	6.5
K=5	A=	0.8	1.0	1.3	1.7	2.1	2.5	3.1	3.7	4.4	5.1	5.9
K=6	A=	0.8	1.0	1.3	1.6	2.0	2.4	2.9	3.5	4.1	4.8	5.5
K=7	A=	0.7	1.0	1.3	1.6	1.9	2.3	2.7	3.3	3.8	4.5	5.2

Integra 165° for corner doors

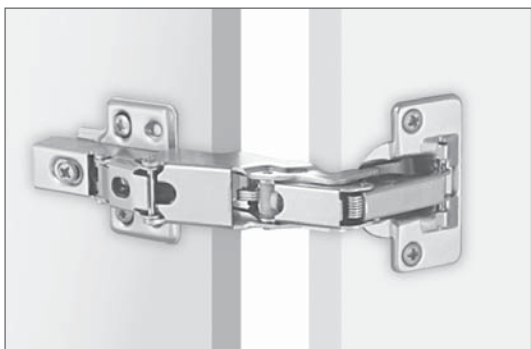

Technical specifications:

- Depth of the metal cup 11.3mm
- Cup diameter 35mm
- Opening 165°
- Possibility of door drilling (K) from 3 to 7 mm
- Thickness of the door (T) from 16 to 26 mm
- SlowMotion solution with linear damper

CRANK 0



CRANK 8



I
A
D

51.BWH5.05.00.0
51.BWH5.05.00.C
51.BWH5.05.00.B

51.BWH5.05.08.0
51.BWH5.05.08.C
51.BWH5.05.08.B



I
A
D

51.BWH6.05.00.M
51.BWH6.05.00.N
51.BWH6.05.00.E

51.BWH6.05.08.M
51.BWH6.05.08.N
51.BWH6.05.08.E



I
A
D

51.BWH6.05.00.0
51.BWH6.05.00.S
51.BWH6.05.00.B

51.BWH6.05.08.0
51.BWH6.05.08.S
51.BWH6.05.08.B

0, B = dowels Ø10mm / S = dowels Ø8mm



I
A
D

51.BWH8.05.00.V
51.BWH8.05.00.S
51.BWH8.05.00.Z

51.BWH8.05.08.V
51.BWH8.05.08.S
51.BWH8.05.08.Z

V, Z = dowels Ø10mm / S = dowels Ø8mm

Versions not damped (code 51.5WH5.05) available for all applications in the above table.

I

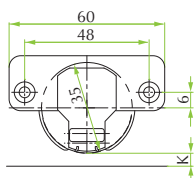

A

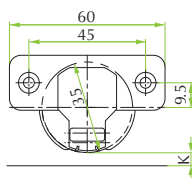

D

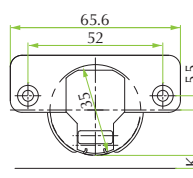

The mounting plates and fittings for this hinge series are shown from page 18 to page 20.

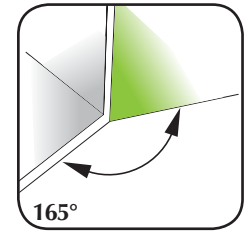
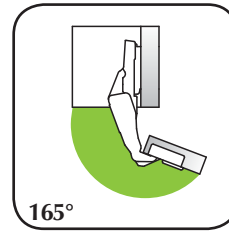

CRANK 0
For lay-on doors

CRANK 8
For partial lay-on doors

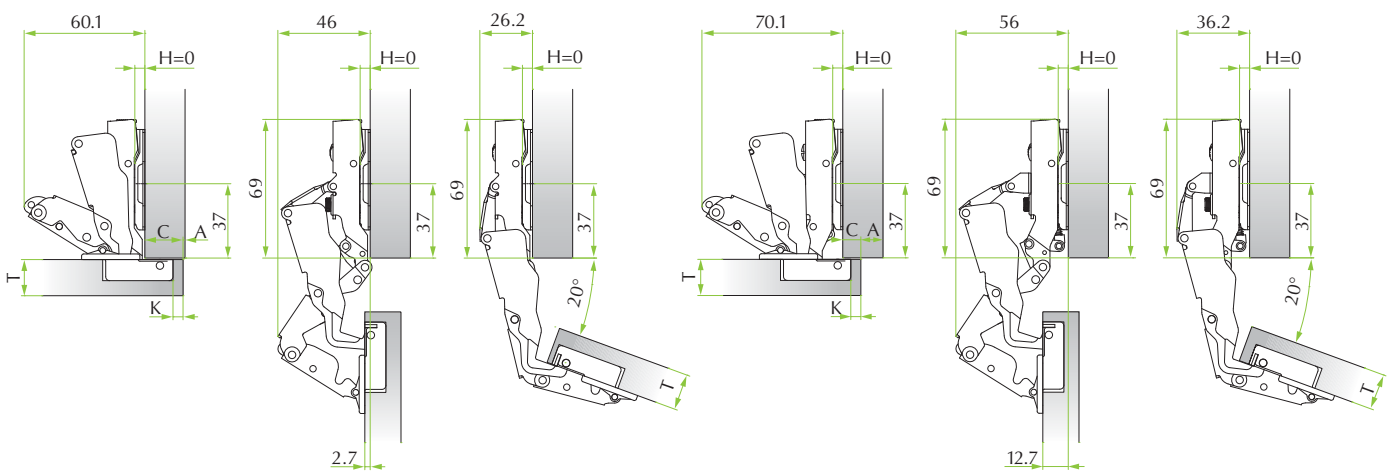

		Drilling distance (K)						
		3	4	5	6	7		
Overlay (C)	21					0		
	20				0			
	19			0	2			
	18		0	2				
	17	0	2					
	16	2						
	15	2						
		Mounting plates (H)						

		Drilling distance (K)						
		3	4	5	6	7		
Overlay (C)	11					0		
	10				0			
	9			0	2			
	8		0	2				
	7	0	2					
	6	2						
	5	2						
		Mounting plates (H)						

Table to determinate the minimum distance A so that a door with T thickness can open without protrusion from the cabinet and without interfering with adjacent doors.

T=	A=	16	17	18	19	20	21	22	23	24	25	26
K=3	A=	0.0	0.0	0.0	0.0	0.0	0.0	0.06	0.19	0.41	0.77	1.31
K=4	A=	0.0	0.0	0.0	0.0	0.0	0.0	0.06	0.21	0.46	0.88	1.57
K=5	A=	0.0	0.0	0.0	0.0	0.0	0.0	0.07	0.52	1.05	1.05	2.13
K=6	A=	0.0	0.0	0.0	0.0	0.0	0.0	0.08	0.62	2.33	2.33	3.33
K=7	A=	0.0	0.0	0.0	0.0	0.0	0.0	0.09	0.75	1.33	1.33	2.33

Integra 105° for corner doors

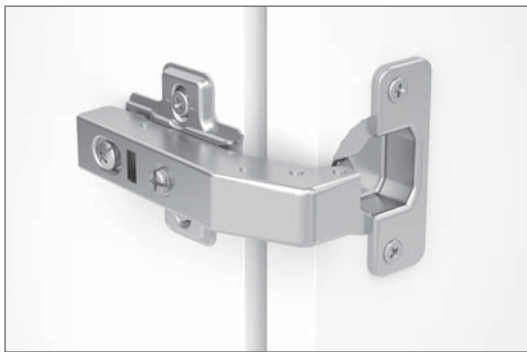

Technical specifications:

- Depth of the metal cup 11.3mm
- Cup diameter 35mm
- Opening 105°
- Possibility of door drilling (K) from 3 to 7 mm
- Thickness of the door (T) from 16 to 26 mm
- SlowMotion solution with linear damper

ANGLE 30°

ANGLE 45°

ANGLE 90°



I
A
D

51.BH85.05.30.0
51.BH85.05.30.C
51.BH85.05.30.B



I
A
D

51.BH86.05.30.M
51.BH86.05.30.N
51.BH86.05.30.E



I
A
D

51.BH86.05.30.0
51.BH86.05.30.S
51.BH86.05.30.B



I
A
D

51.BH88.05.30.V
51.BH88.05.30.S
51.BH88.05.30.Z

51.BH85.05.45.0
51.BH85.05.45.C
51.BH85.05.45.B

51.BH86.05.45.M
51.BH86.05.45.N
51.BH86.05.45.E

51.BH86.05.45.0
51.BH86.05.45.S
51.BH86.05.45.B

51.BH88.05.45.V
51.BH88.05.45.S
51.BH88.05.45.Z

51.BH85.05.90.0
51.BH85.05.90.C
51.BH85.05.90.B

51.BH86.05.90.M
51.BH86.05.90.N
51.BH86.05.90.E

51.BH86.05.90.0
51.BH86.05.90.S
51.BH86.05.90.B

51.BH88.05.90.V
51.BH88.05.90.S
51.BH88.05.90.Z

0, B = dowels Ø10mm / S = dowels Ø8mm

V, Z = dowels Ø10mm / S = dowels Ø8mm

Versions not damped (code 51.5H85.05) available for all applications in the above table.

I

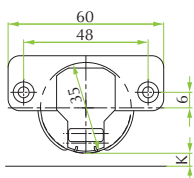

A

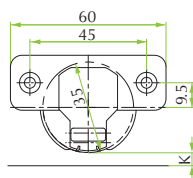

D

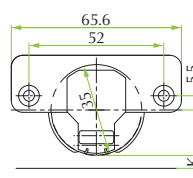

The mounting plates and fittings for this hinge series are shown from page 18 to page 20.

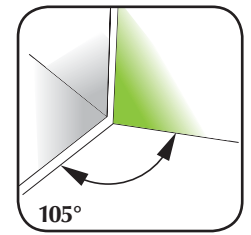
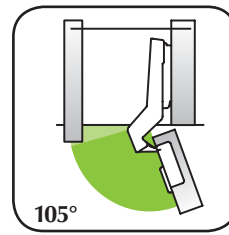

ANGLE 30°

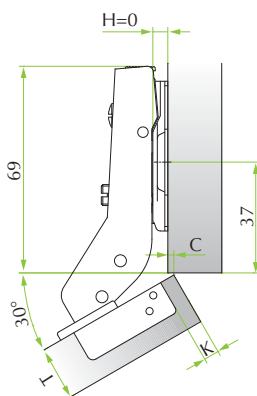

ANGLE 45°

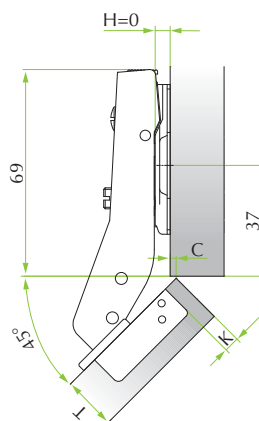

ANGLE 90°

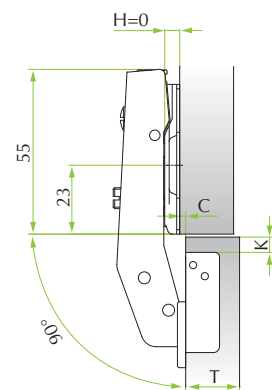
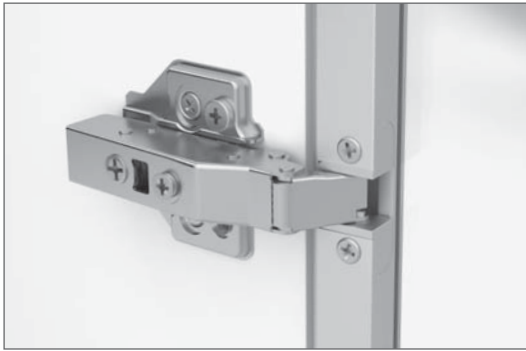

Table to determinate the minimum distance **A** so that a door with **T** thickness can open without protrusion from the cabinet and without interfering with adjacent doors.

	T=	16	17	18	19	20	21	22	23	24	25	26
K=3	A=	0.9	1.1	1.5	1.8	2.3	2.8	3.6	4.3	5.2	6.0	6.9
K=4	A=	0.8	1.1	1.4	1.8	2.2	2.7	3.3	4.0	4.7	5.5	6.5
K=5	A=	0.8	1.0	1.3	1.7	2.1	2.5	3.1	3.7	4.4	5.1	5.9
K=6	A=	0.8	1.0	1.3	1.6	2.0	2.4	2.9	3.5	4.1	4.8	5.5
K=7	A=	0.7	1.0	1.3	1.6	1.9	2.3	2.7	3.3	3.8	4.5	5.2

Integra 105° for doors with aluminium frame



Technical specifications:

- Depth of the zamak cup 9.9mm
- Cup drilling 28x7mm
- Opening 105°
- Aluminium frame from min. 19 to max 25 mm
- SlowMotion solution with linear damper

FIXING FOR GROOVED PROFILE

CRANK 0



51.BS91.05.00.0

CRANK 8



51.BS91.05.08.0

CRANK 15



51.BS91.05.15.0

Versions not damped (code 51.5S91.05) available for all applications in the above table.

Drilling holes:

The two laterals drillings are $\varnothing 4$ mm and are countersunk with 120°. Screws $\varnothing 3.5 \times 12$ mm supplied on demand under code 1A05512105000.

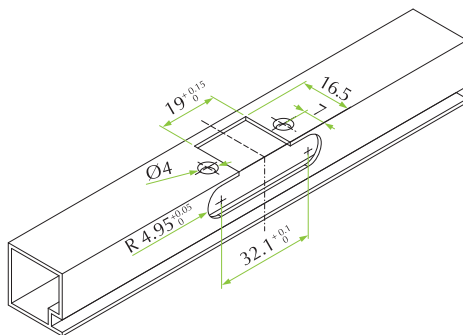

Assembly instructions:

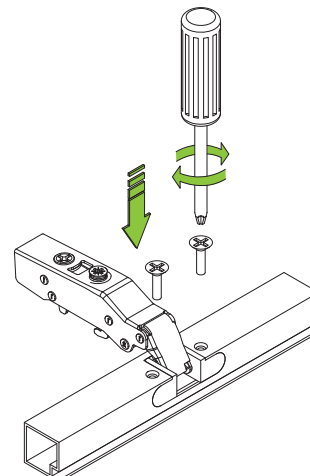
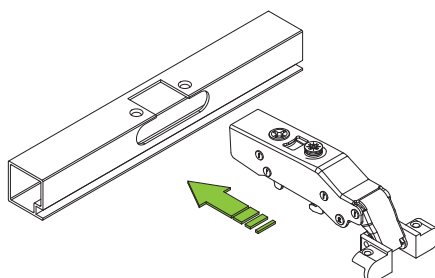

The mounting plates and fittings for this hinge series are shown from page 18 to page 20.

Metal cruciform mounting plate. Selftapping screw fixing. Vertical adjustment.
Screws provided upon request.

37

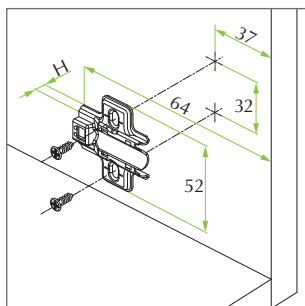

Height	Material	Code
H=0	Steel	52.5B01.M5.00.0
H=2	Steel	52.5B01.M5.02.0
H=4	Steel	52.5B01.M5.04.0

Metal cruciform mounting plate. Euro screws premounted. Vertical adjustment.

37

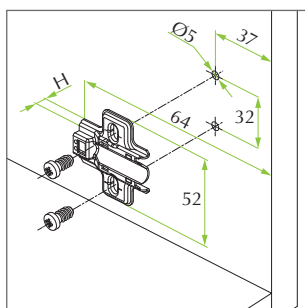

Height	Material	Code
H=0	Steel	52.5B16.M5.00.*
H=2	Steel	52.5B16.M5.02.*
H=4	Steel	52.5B16.M5.04.*

* A = B = G =

Metal cruciform mounting plate. Knock-in fixing with dowels Ø8mm. Vertical adjustment.

37

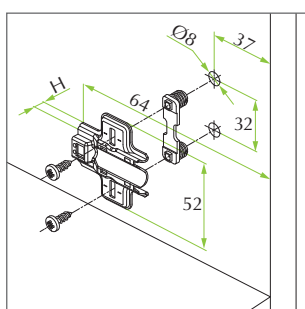
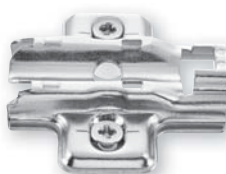

Height	Material	Code
H=0	Steel	52.5BC5.M5.00.0
H=2	Steel	52.5BC5.M5.02.0
H=4	Steel	52.5BC5.M5.04.0

C =

Metal cruciform mounting plate. Knock-in fixing with dowels Ø10mm. Vertical adjustment.

37

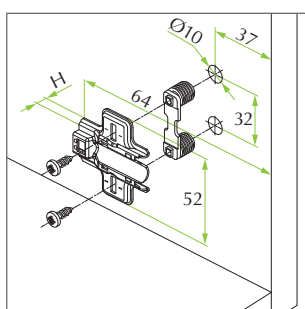

Height	Material	Code
H=0	Steel	52.5BD5.M5.00.0
H=2	Steel	52.5BD5.M5.02.0
H=4	Steel	52.5BD5.M5.04.0

D =

Metal cruciform mounting plate. Selftapping screw fixing. Independent vertical adjustment with CAM.
Screws provided upon request.

37

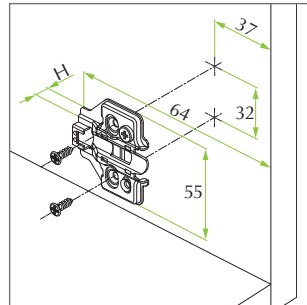
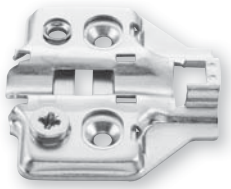



Height	Material	Code
H=0	Steel	52.RB44.L5.00.0
H=2	Steel	52.RB44.L5.02.0
H=4	Steel	52.RB44.L5.04.0

Metal cruciform mounting plate. Euro screws premounted. Independent vertical adjustment with CAM.

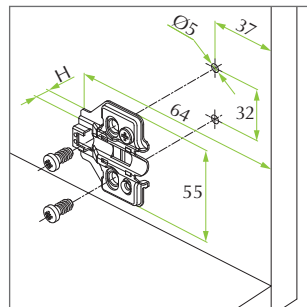
37



Height	Material	Code
H=0	Steel	52.RB47.L5.00.*
H=2	Steel	52.RB47.L5.02.*
H=4	Steel	52.RB47.L5.04.*

* A =  B =  C = 

Metal cruciform mounting plate. Knock-in fixing with dowels Ø8mm. Independent vertical adjustment with CAM.

37

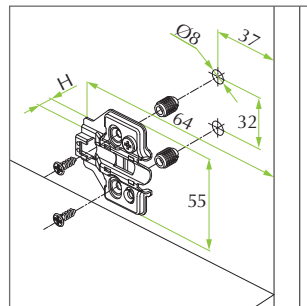
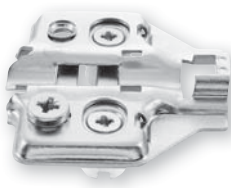

Height	Material	Code
H=0	Steel	52.RBC5.L5.00.0
H=2	Steel	52.RBC5.L5.02.0
H=4	Steel	52.RBC5.L5.04.0

C = 

Metal cruciform mounting plate. Knock-in fixing with dowels Ø10mm. Independent vertical adjustment with CAM.

37

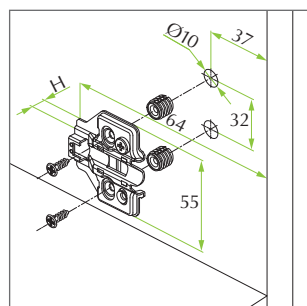
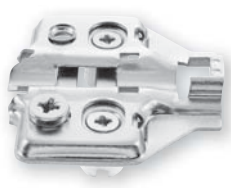

Height	Material	Code
H=0	Steel	52.RBD5.M5.00.0
H=2	Steel	52.RBD5.M5.02.0
H=4	Steel	52.RBD5.M5.04.0

D = 

Arm cover cap.



Material	Code
Steel	51.0Y.0005.000000N
Steel with FGV logo*	51.0YFGV.5.0000000

*Customer logo upon request.

Hinge box cover cap.



Cup hole dist.	Material	Code
48-45	Steel	51.5CB0.05.00000
52	Steel	51.5CB0.05.00B00

Ø35mm cover.



Material	Code
Nylon	5307C3**00000

** Colour code: A1 = White RAL 9010 / A2 = Brown RAL 8016 / C6 = Grey RAL 7004 / OI = Painted matt aluminium

HINGES

Fixing System



SELFTAPPING SCREW



EURO SCREW



DOWEL



VELOFIX DOWEL

Cup hole distance

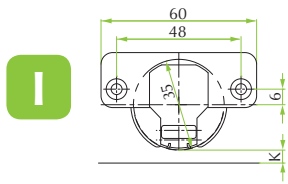

CUP HOLE DISTANCE 48x6mm

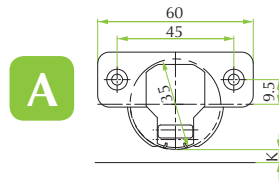

CUP HOLE DISTANCE 45x9.5mm

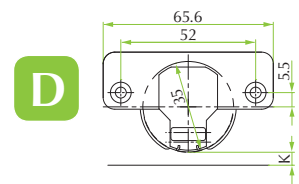

CUP HOLE DISTANCE 52x5.5mm

Angles

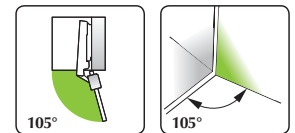
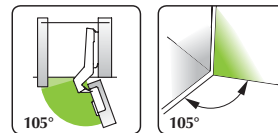
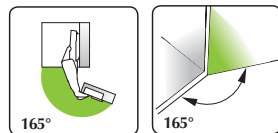
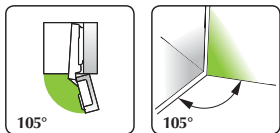

MOUNTING PLATES

Fixing System



SELFTAPPING SCREW



EURO SCREW



DOWEL

37

DRILLING DISTANCE 37mm

Notes

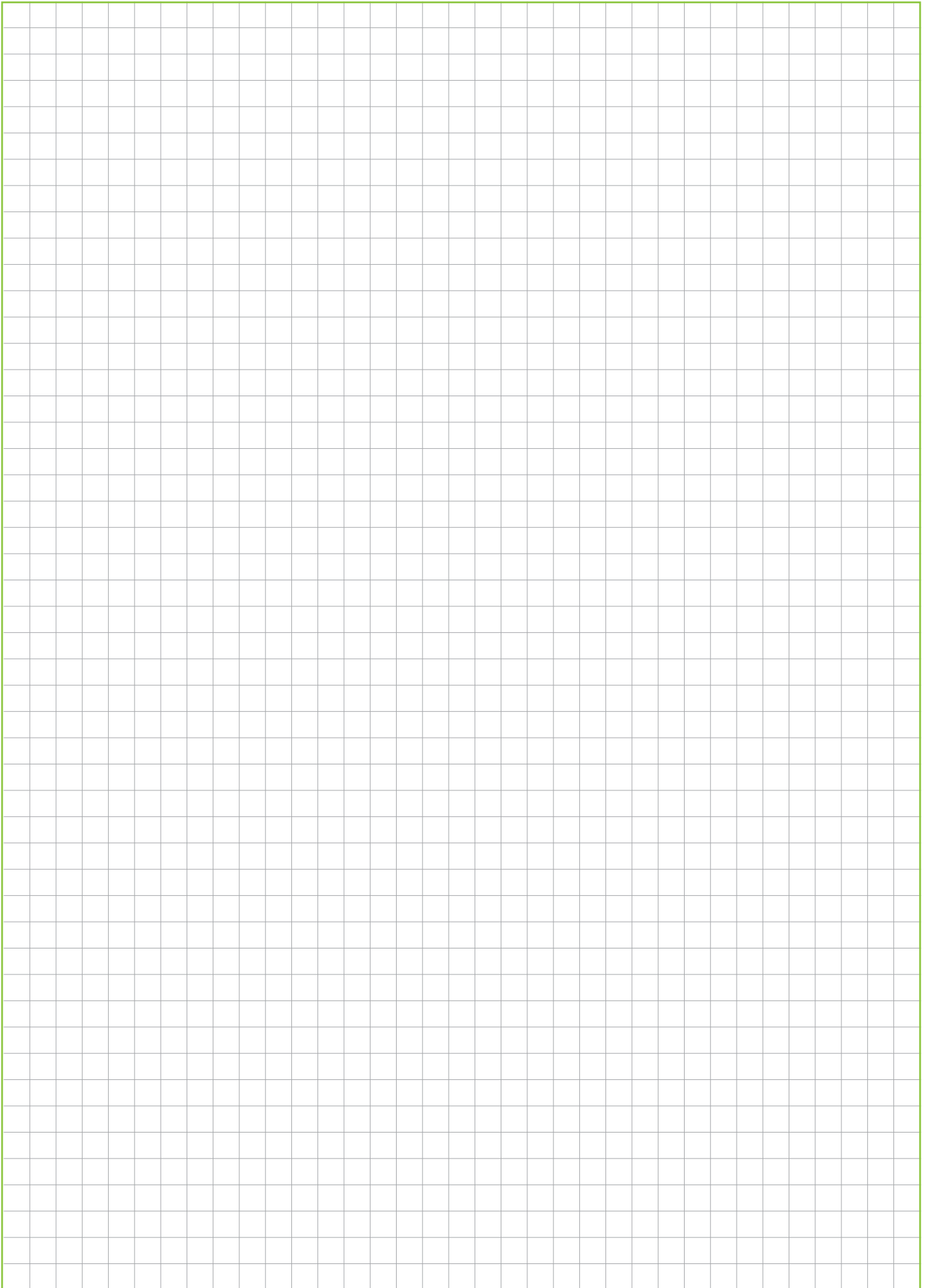

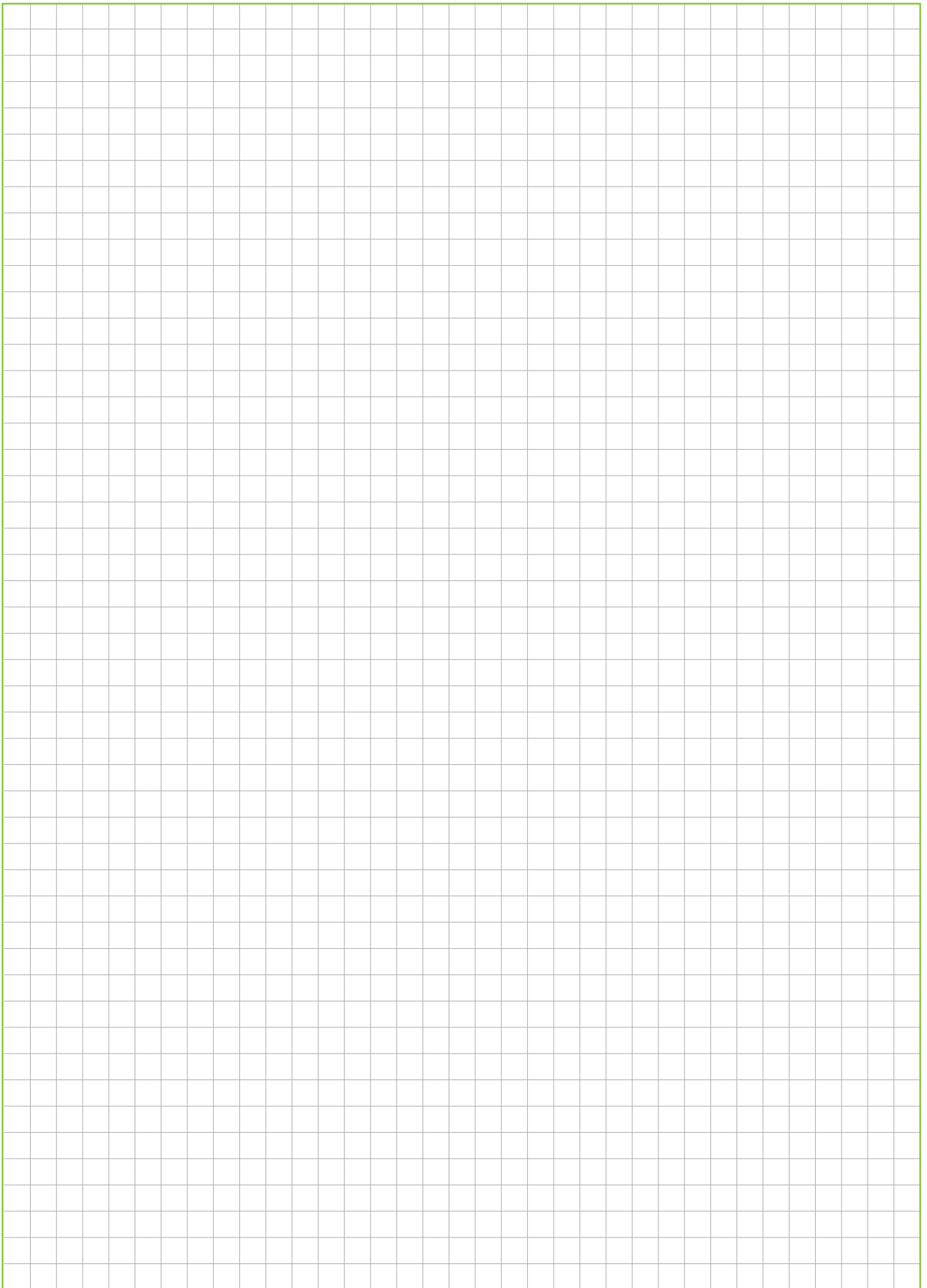

FORMENTI & GIOVENZANA S.p.A.

Via Concordia, 16
 20837 Veduggio con Colzano (MB) - ITALY
 Tel. +39 0362 947.1 r.a. - Fax +39 0362 998788
 info@fgv.it
 www.fgv.it

FGV SLOVAKIA, Spol s r.o.

Partizánska cesta 73, P.O.BOX 87
 957 01 Bánovce nad Bebravou - SLOVAKIA
 Tel. +421 (0) 38 7626 100 - Fax +421 (0) 38 7626 105
 info@fgv.sk

FGVTN BRASIL LTDA.

Rua Francisco Derosso, 1352
 Curitiba Paraná 81710 000 - BRASIL
 Tel. +55 41 2107 4411 - Fax +55 41 3275 3038
 fgvtn@fgvtnbrasil.com.br - www.fgvtnbrasil.com.br

FGV ASIA Limited

Unit 1602, 16/F., Metropolis Tower
 10 Metropolis Drive, Hunghom,
 Kowloon, Hong Kong - P.R.CHINA
 Tel. +852 2762 1534 - Fax +852 2648 7389
 info@fgvasia.com - www.fgvasia.com

FGV (Guangzhou) Company Limited

Units 2710-2711, Yang Cheng International Trading Centre
 East Tower, Ti Yu Dong Lu, No. 122
 Guangzhou - P R CHINA
 Tel. +86 20 38870570 - Fax +86 20 38870323
 info@fgvchina.com - www.fgvchina.com

DEUTSCHE FGV Formenti & Giovenzana Möbelbeschläge GmbH

Industriestr. 44
 D-33397 Rietberg - GERMANY
 Tel. +49 (0) 5244-9708-0 - Fax +49 (0) 5244-9708-15
 www.fgvgermany.com

FORMENTI & GIOVENZANA POLSKA Sp. z o.o.

Ul. Boleslawiecka 8a
 98-400 Wieruszów - POLAND
 Tel. +48 62 58 10 400 - Fax +48 62 58 10 480
 www.fgvpolka.pl

FGV UKRAINE TOB

Вул. Черновола 39
 08132 Вишневе, Київська обл., Україна
 Тел. +38 044 333 56 23
 Факс +38 044 333 56 24
 info@fgv.kiev.ua

FGV SERVICE VENETO S.r.l.

Via Pietro Bassani, 12
 33170 Pordenone (PN) - ITALY
 Tel. +39 0434 572728
 infoveneto@fgvservice.com

FGV SERVICE CENTRO-SUD

Via Massimo d'Antona, 6i
 60033 Chiaravalle (AN) - ITALY
 Tel. +39 071 7451125 - Fax +39 071 7496441
 infocentrosud@fgvservice.com