

Technical specifications:

- Upwards assisted lifter
- Covers 85°, 90° and 95° angles
- 32 mm standard cabinet drilling
- Assisted opening
- Possible to combine with OneTouch mechanism for handleless application

SINGLE KIT

Code	Description	Force	Packing
59.5K10.06.040.3000	Kit AeroLift - up solution	40N	100 kits per box
59.5K10.06.060.3000	Kit AeroLift - up solution	60N	100 kits per box
59.5K10.06.080.3000	Kit AeroLift - up solution	80N	100 kits per box
59.5K10.06.100.3000	Kit AeroLift - up solution	100N	100 kits per box
59.5K10.06.120.3000	Kit AeroLift - up solution	120N	100 kits per box

Packed in a kit, consists of:

- 1 gas spring AeroLift up solution
- 1 bracket for cabinet
- 1 bracket for wooden door
- 1 bracket for aluminium frame
- 5 selftapping screws Ø3.5x15 mm
- 2 flathead selftapping screws Ø3.5x15 mm
- Assembly instructions

INDUSTRIAL PACKING

Code	Description	Force	Packing
59.5100.06.040.3010	Gas spring AeroLift - up solution	40N	1000 pcs per box
59.5100.06.060.3010	Gas spring AeroLift - up solution	60N	1000 pcs per box
59.5100.06.080.3010	Gas spring AeroLift - up solution	80N	1000 pcs per box
59.5100.06.100.3010	Gas spring AeroLift - up solution	100N	1000 pcs per box
59.5100.06.120.3010	Gas spring AeroLift - up solution	120N	1000 pcs per box
59.5ASP.05.000.00	Bracket for cabinet without dowels	-	1000 pcs per box
59.5ASP.05.000.0A	Bracket for cabinet with dowels	-	1000 pcs per box
59.5ALP.05.000.00	Bracket for wooden door	-	1000 pcs per box
59.5AAP.05.000.00	Bracket for aluminium frame	-	1000 pcs per box
59.5AAP.05.000.0A	Bracket for aluminium frame with Euro screws	-	1000 pcs per box



Bracket for cabinet

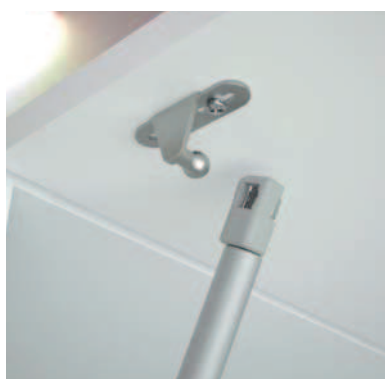

Bracket for wooden door

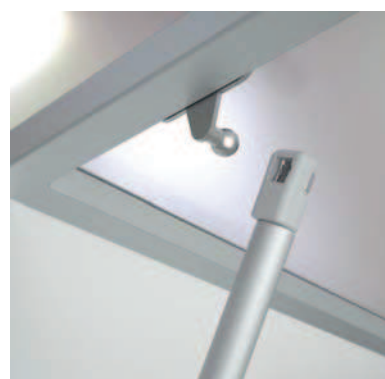

Bracket for door with frame

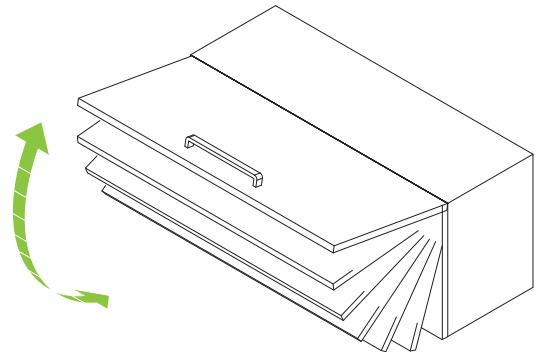

Up solution application:

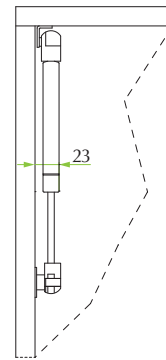
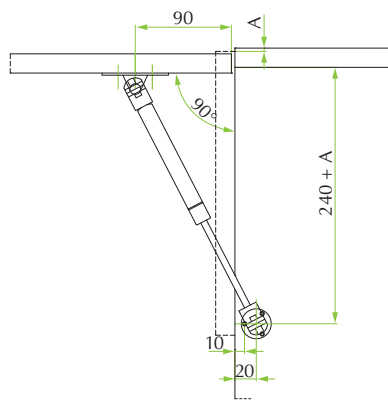
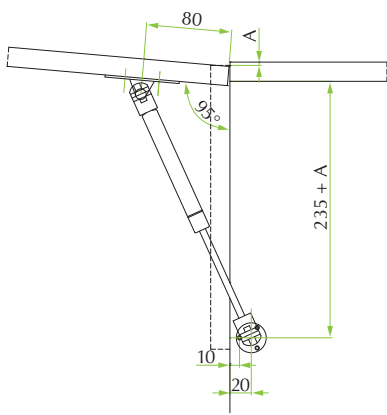

Door fixing

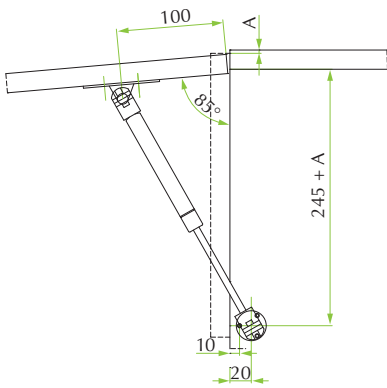
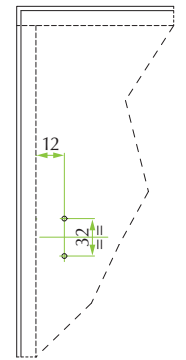

A	X	Y
<90°	100	245
90°	90	240
>90°	80	235

OneTouch application:

With magnet and push hinges

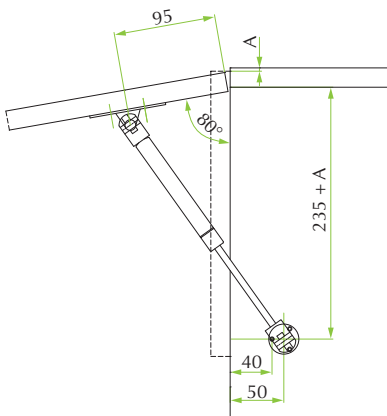

With long version and standard hinges

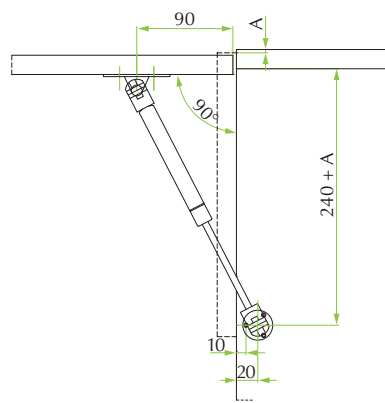

Technical details about OneTouch devices are shown from page 144 to page 147.

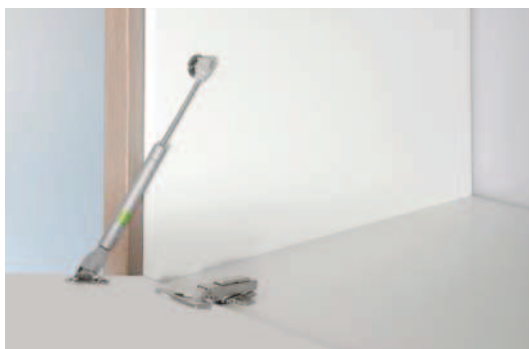

Technical specifications:

- Downwards assisted lifter
- Angles 90°
- 32mm standard cabinet drilling
- Assisted opening and SlowMotion closing
- Possible to combine with OneTouch mechanism for handle less application

SINGLE KIT

Code	Description	Force	Packing
59.5K20.06.060.3000	Kit AeroLift - down solution	60N	100 kits per box
59.5K20.06.080.3000	Kit AeroLift - down solution	80N	100 kits per box
59.5K20.06.100.3000	Kit AeroLift - down solution	100N	100 kits per box
59.5K20.06.120.3000	Kit AeroLift - down solution	120N	100 kits per box

Packed in a kit, consists of:

- 1 gas spring AeroLift down solution
- 1 bracket for cabinet
- 1 bracket for wooden door
- 1 bracket for aluminium frame
- 5 selftapping screws Ø3.5x15 mm
- 2 flathead selftapping screws Ø3.5x15 mm
- Assembly instructions

INDUSTRIAL PACKING

Code	Description	Force	Packing
59.5200.06.060.3010	Gas spring AeroLift - down solution	60N	1000 pcs per box
59.5200.06.080.3010	Gas spring AeroLift - down solution	80N	1000 pcs per box
59.5200.06.100.3010	Gas spring AeroLift - down solution	100N	1000 pcs per box
59.5200.06.120.3010	Gas spring AeroLift - down solution	120N	1000 pcs per box
59.5ASP.05.000.00	Bracket for cabinet without dowels	–	1000 pcs per box
59.5ASP.05.000.0A	Bracket for cabinet with dowels	–	1000 pcs per box
59.5ALP.05.000.00	Bracket for wooden door	–	1000 pcs per box
59.5AAP.05.000.00	Bracket for aluminium frame	–	1000 pcs per box
59.5AAP.05.000.0A	Bracket for aluminium frame with Euro screws	–	1000 pcs per box

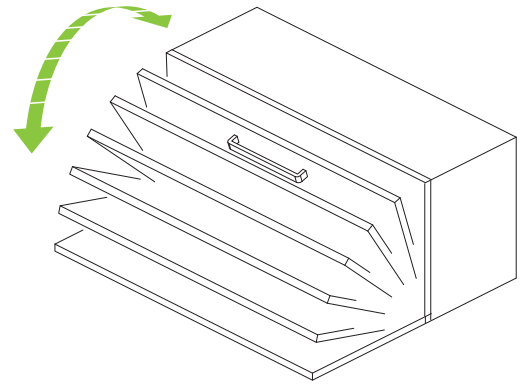

Down solution application:

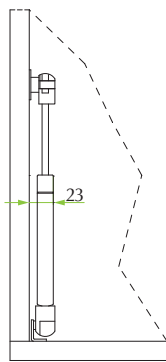
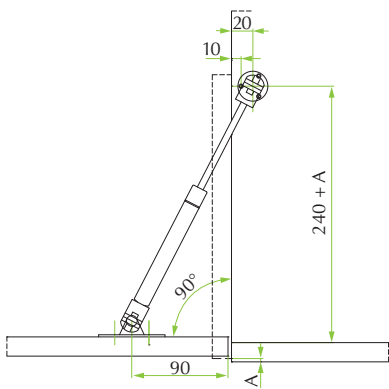

Door fixing

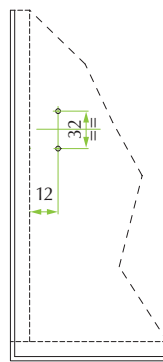

OneTouch application:

Compatible with all the FGV OneTouch devices available

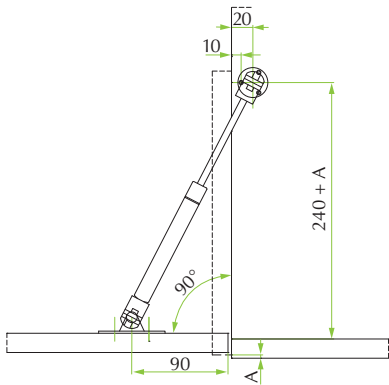

Technical details about OneTouch devices are shown from page 144 to page 147.