



Alternative openings



Aero is the FGV alternative openings line.

Aero application confers a linear and high-end visual appeal to the furniture with a natural and impressive door movement. The complete range of solutions guarantees full accessibility to the cabinet interior, compatibility with low-ceilinged rooms or with large, high-ceilinged spaces, and with cabinet fronts that tilt out and lift upwards.



Linear minimalistic design

Modern kitchen design is linear and minimalist. Large drawers in the base cabinets are asking for corresponding design elements in the wall hanging cabinets.

Aero lifter systems are the affordable up-to-date solutions to create a linear look and to enhance the impact of the whole cabinet.

One gesture full access

Aero lifter systems are the response of FGV to give immediate access in one movement to the full space of wall hanging cabinets. The slim housing and non-invasive look of the products ensures full accessibility to the cabinet content.



Elegant movement

Many applications. Self lifting movement, self holding with final damping for soft closure.



Full range of solutions

The choice of the appropriate AeroBus / AeroFlap / AeroLoft / AeroSplit / AeroWing / AeroLift mechanism depends on the size and the weight of the door. With lift, fold-up or swing over the large door the full space is always accessible in one go.





AeroBus



AeroFlap



AeroLoft



AeroSplit

Aero Index



AeroBus

Upwards operation

174-175



AeroFlap

Moving above

176-177



AeroLoft

Moving up

178-179



AeroSplit

Folding up

180-181



AeroWing

The three in one

182-183



AeroLift

Upwards Assisted lifter

184-185



AeroLift

Downwards assisted lifter

186-187



AeroWing



AeroLift



Technical specifications:

- Upwards operation
- Easy and rapid assembly with click-on door fixing
- No hinges required
- No stabilization bar required
- Door and weight adjustments
- SlowMotion technology for controlled and silent closing

Code	Description	Kit	Door Height (mm)	Door Weight (Kg)	Packing
59.0VBS.A9.D20.0000	Kit AeroBus	D20	180	2.2 - 5.5	10 kits per box
			250	1.6 - 4.0	
			300	1.3 - 3.5	
			400	1.0 - 2.5	
59.0VBS.A9.D40.0000	Kit AeroBus	D40	180	5.3 - 12.3	10 kits per box
			250	3.8 - 8.9	
			300	3.2 - 7.4	
			400	2.4 - 5.5	

Packed in a kit, consists of:

- 2 symmetrical and damped mechanisms
- 2 covers, RH and LH
- 2 click mounting plates
- 6 selftapping screws Ø4x15 mm
- 8 selftapping screws Ø4x35 mm
- Assembly instructions



AeroBus Video

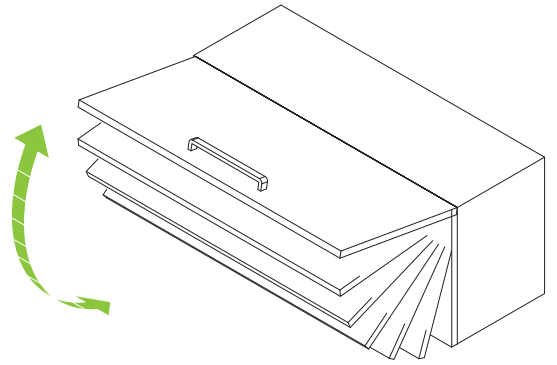

Application:

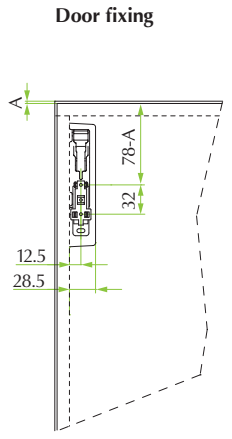
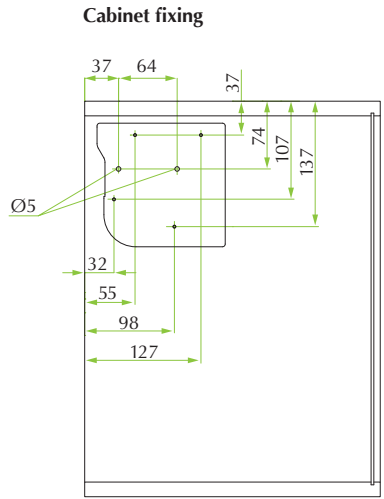
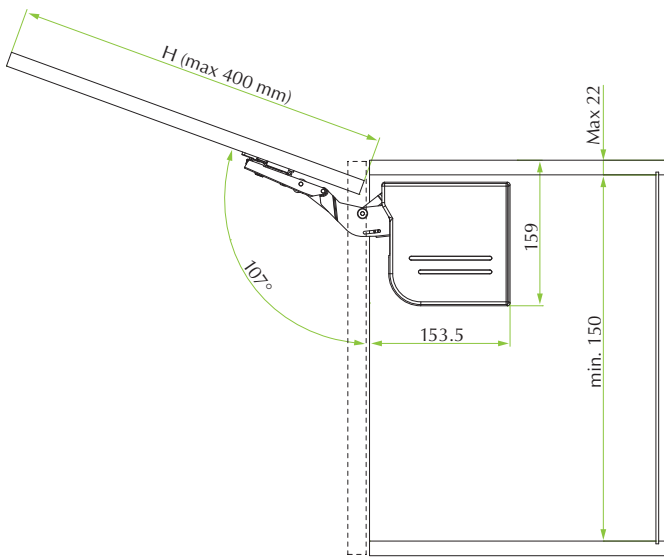

Adjustments:

Door adjustment

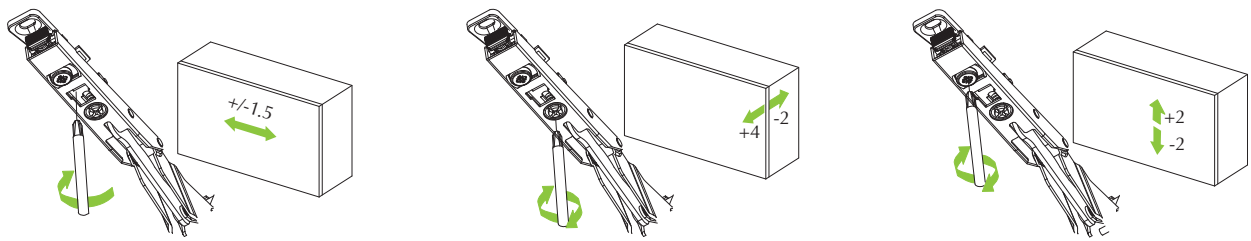

Weight adjustment

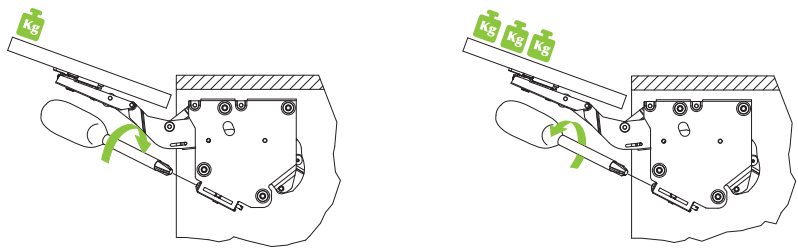



Technical specifications:

- Moving above solution
- Perfect stay in every opening position
- 3D adjustments for door positioning
- SlowMotion technology for controlled and silent closing

Code	Description	Kit	Door Height (mm)	Door Weight (Kg)	Packing
59.0VFL.A9.R10.0000	Kit AeroFlap	R10	450	4.8 - 5.7	1 kit per box
			600	4.4 - 5.2	
			660	4.0 - 4.7	
59.0VFL.A9.R20.0000	Kit AeroFlap	R20	450	5.8 - 7.3	1 kit per box
			600	5.3 - 6.7	
			660	4.8 - 6.2	
59.0VFL.A9.R30.0000	Kit AeroFlap	R30	450	7.4 - 9.2	1 kit per box
			600	6.8 - 8.4	
			660	6.3 - 7.9	
59.0VFL.A9.R40.0000	Kit AeroFlap	R40	450	9.3 - 10.8	1 kit per box
			600	8.5 - 9.9	
			660	8.0 - 9.3	
59.0VFL.A9.R50.0000	Kit AeroFlap	R50	450	10.9 - 14.5	1 kit per box
			600	10.0 - 13.0	
			660	9.4 - 11.8	
59.0VFL.A9.S10.0000	Kit AeroFlap	S10	720	4.6 - 6.2	1 kit per box
			800	4.5 - 5.9	
59.0VFL.A9.S20.0000	Kit AeroFlap	S20	720	6.3 - 7.8	1 kit per box
			800	6.0 - 7.6	
59.0VFL.A9.S30.0000	Kit AeroFlap	S30	720	7.9 - 9.3	1 kit per box
			800	7.7 - 8.9	
59.0VFL.A9.S40.0000	Kit AeroFlap	S40	720	9.5 - 12.0	1 kit per box
			800	9.0 - 11.4	

Packed in a kit, consists of:

- 2 mechanisms, RH and LH
- 2 dampers for the mechanisms
- 2 covers, RH and LH
- 2 cover caps
- 14 Euro screws Ø6x12 mm
- 12 selftapping screws Ø4x35 mm
- Assembly instructions

Stabilization bar required to be ordered separately.

Code	Description
59.0VB0.0A.2000.000	Stabilization bar - 2m length

Stabilization bar to be cut to size. (Bar dimension = internal cabinet dimension – 25mm)

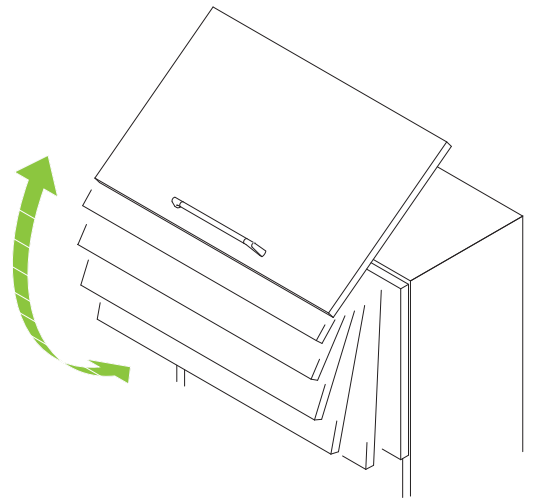

Application:

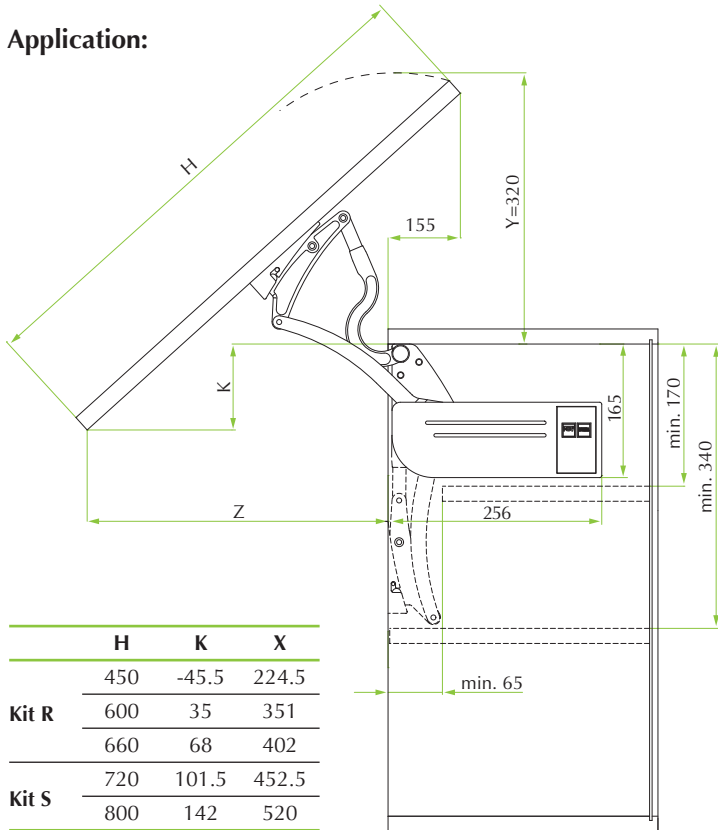

	H	K	X
	450	-45.5	224.5
Kit R	600	35	351
	660	68	402
	720	101.5	452.5
Kit S	800	142	520

Cabinet fixing

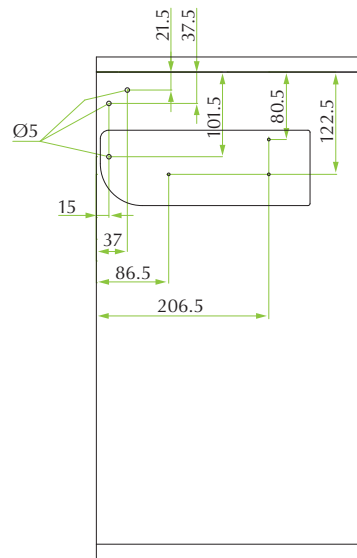

Door fixing

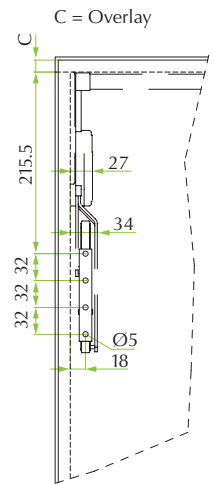

Adjustments:

Door adjustment

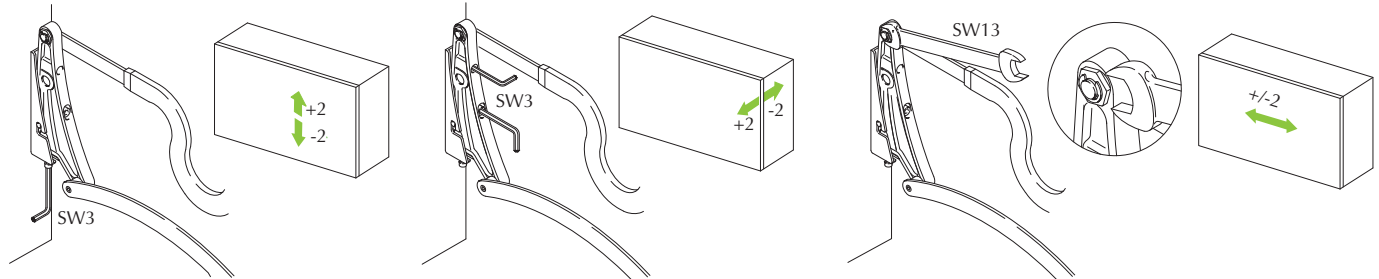

Weight adjustment

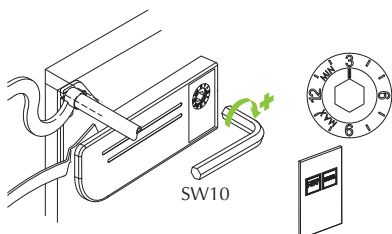



Technical specifications:

- Moving up solution
- Perfect stay in every position
- 3D adjustments for door positioning
- SlowMotion technology for controlled and silent closing

Code	Description	Kit	Door Height (mm)	Door Weight (Kg)	Packing
59.0VLT.A9.K08.0000	Kit AeroLoft	K08	350-400	2.6 - 3.5	1 kit per box
59.0VLT.A9.K09.0000	Kit AeroLoft	K09		3.6 - 4.7	1 kit per box
59.0VLT.A9.K10.0000	Kit AeroLoft	K10		4.8 - 6.0	1 kit per box
59.0VLT.A9.K20.0000	Kit AeroLoft	K20	380-500	6.1 - 7.6	1 kit per box
59.0VLT.A9.K30.0000	Kit AeroLoft	K30		7.7 - 9.8	1 kit per box
59.0VLT.A9.K40.0000	Kit AeroLoft	K40		9.9 - 11.4	1 kit per box
59.0VLT.A9.K50.0000	Kit AeroLoft	K50		11.5 - 14.6	1 kit per box
59.0VLT.A9.L10.0000	Kit AeroLoft	L10	450-580	4.7 - 5.9	1 kit per box
59.0VLT.A9.L20.0000	Kit AeroLoft	L20		6.0 - 7.6	1 kit per box
59.0VLT.A9.L30.0000	Kit AeroLoft	L30		7.7 - 9.2	1 kit per box
59.0VLT.A9.L40.0000	Kit AeroLoft	L40		9.3 - 11.6	1 kit per box
59.0VLT.A9.M10.0000	Kit AeroLoft	M10	550-660	5.3 - 6.6	1 kit per box
59.0VLT.A9.M20.0000	Kit AeroLoft	M20		6.7 - 7.9	1 kit per box
59.0VLT.A9.M30.0000	Kit AeroLoft	M30		8.0 - 10.3	1 kit per box

Packed in a kit, consists of:

- 2 mechanisms, RH and LH
- 2 dampers for the mechanisms
- 2 covers, RH and LH
- 2 cover caps
- 14 Euro screws Ø6x12 mm
- 12 selftapping screws Ø4x35 mm
- Assembly instructions

Stabilization bar required to be ordered separately.

Code	Description
59.0VB0.0A.2000.000	Stabilization bar - 2m length

Stabilization bar to be cut to size. (Bar dimension = internal cabinet dimension - 25mm)

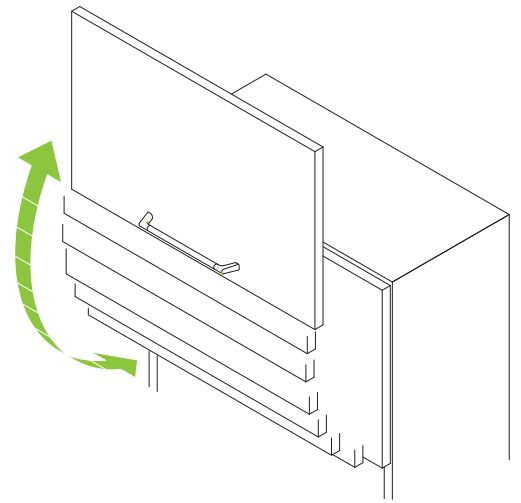

Application:

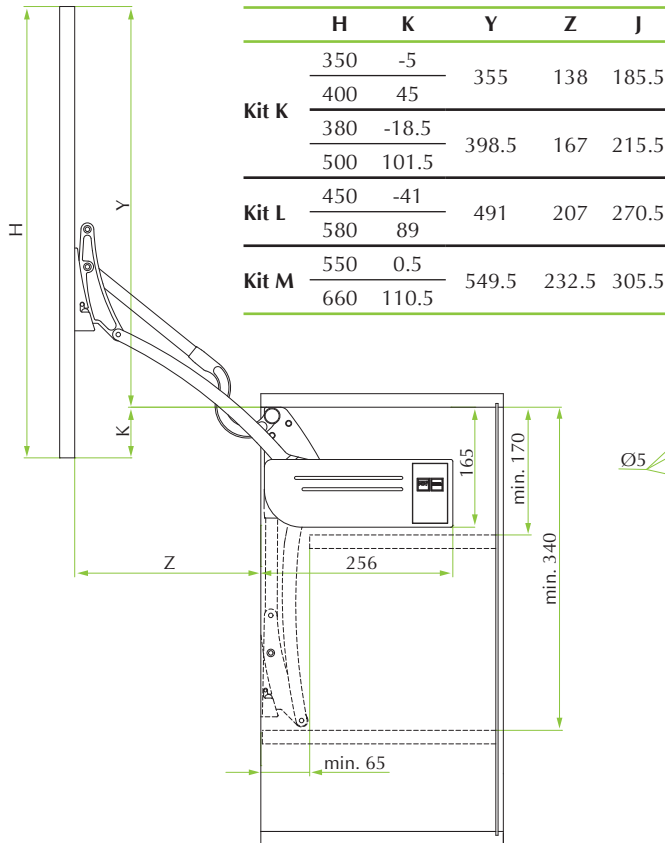

Cabinet fixing

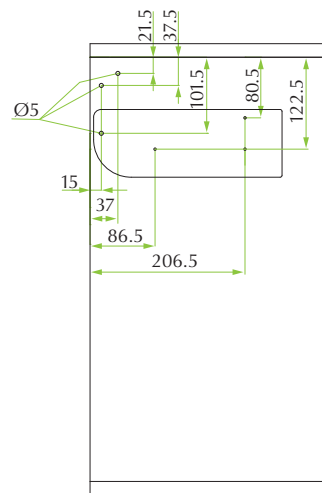

Door fixing

C = Overlay

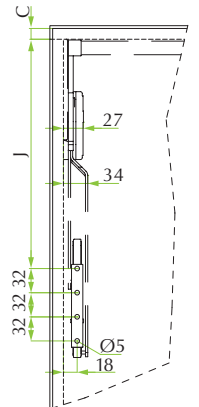

Adjustments:

Door adjustment

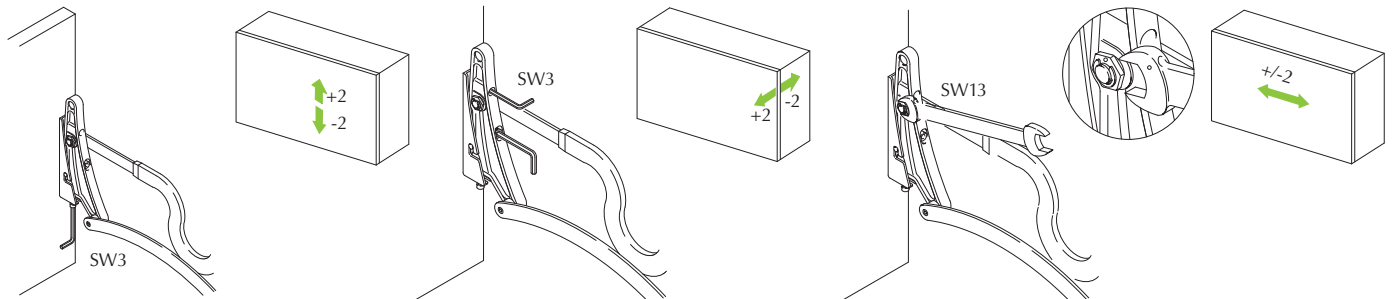

Weight adjustment

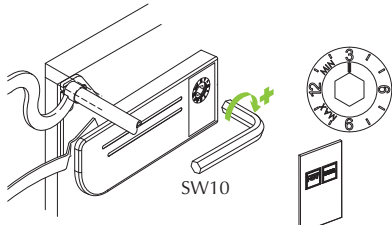



Technical specifications:

- Folding up solution
- 125° folding door opening operation, ensuring the second half of the door folds extremely flat
- Anti-pinch central hinge for safe functioning
- No stabilization bar required
- Perfect stay in every position
- SlowMotion technology for controlled and silent closing

Code	Description	Kit	Door Height (mm)	Door Weight (Kg)	Packing
59.0VSP.A9.A10.0000	Kit AeroSplit	A10	600	6.0 - 6.7	1 kit per box
59.0VSP.A9.A20.0000	Kit AeroSplit	A20		6.8 - 8.1	1 kit per box
59.0VSP.A9.A30.0000	Kit AeroSplit	A30		8.2 - 10.0	1 kit per box
59.0VSP.A9.A40.0000	Kit AeroSplit	A40		10.1 - 13.0	1 kit per box
59.0VSP.A9.A50.0000	Kit AeroSplit	A50		13.1 - 16.2	1 kit per box
59.0VSP.A9.B10.0000	Kit AeroSplit	B10	720	5.3 - 6.5	1 kit per box
59.0VSP.A9.B20.0000	Kit AeroSplit	B20		6.6 - 8.7	1 kit per box
59.0VSP.A9.B30.0000	Kit AeroSplit	B30		8.8 - 11.0	1 kit per box
59.0VSP.A9.B40.0000	Kit AeroSplit	B40		11.1 - 13.3	1 kit per box
59.0VSP.A9.B50.0000	Kit AeroSplit	B50		13.4 - 14.8	1 kit per box
59.0VSP.A9.C10.0000	Kit AeroSplit	C10	800	5.0 - 6.1	1 kit per box
59.0VSP.A9.C20.0000	Kit AeroSplit	C20		6.2 - 8.0	1 kit per box
59.0VSP.A9.C30.0000	Kit AeroSplit	C30		8.1 - 10.0	1 kit per box
59.0VSP.A9.C40.0000	Kit AeroSplit	C40		10.1 - 12.5	1 kit per box
59.0VSP.A9.C50.0000	Kit AeroSplit	C50		12.6 - 13.5	1 kit per box

Packed in a kit, consists of:

- 2 mechanisms, RH and LH
- 2 dampers for the mechanisms
- 2 brackets for the mechanisms, RH and LH
- 2 covers, RH and LH
- 2 covers cap
- 2 central hinges
- 14 Euro screws Ø6.3x12 mm
- 12 selftapping screws Ø4x35 mm
- Assembly instructions

Hinges 125° not included.

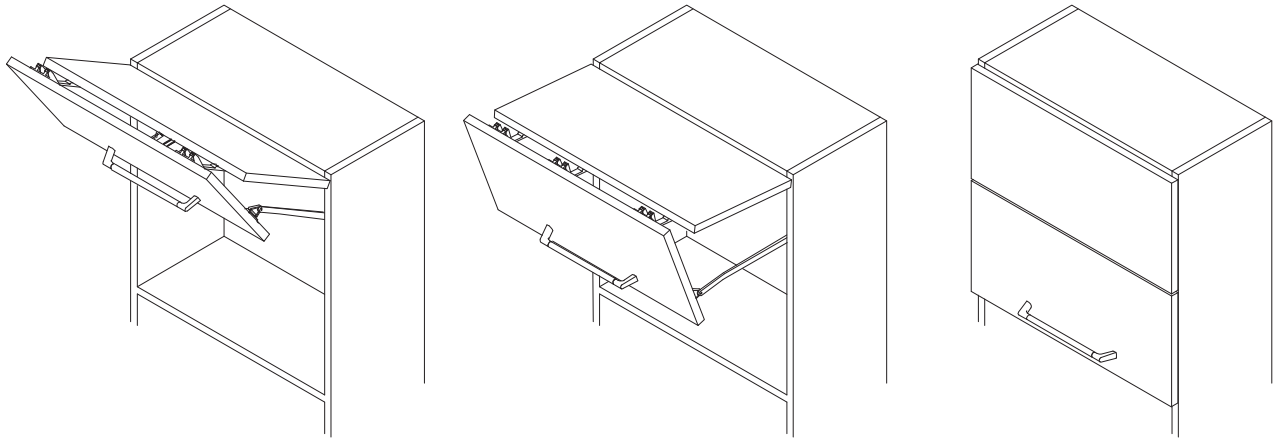

Application 125°:

	H	K	Y	Z	T	V	U	X
Kit A	600	75	161	383	314	335	356	270
Kit B	720	91	181	450	367	388	409	323
Kit C	800	119	210.5	468	398	419	440	354

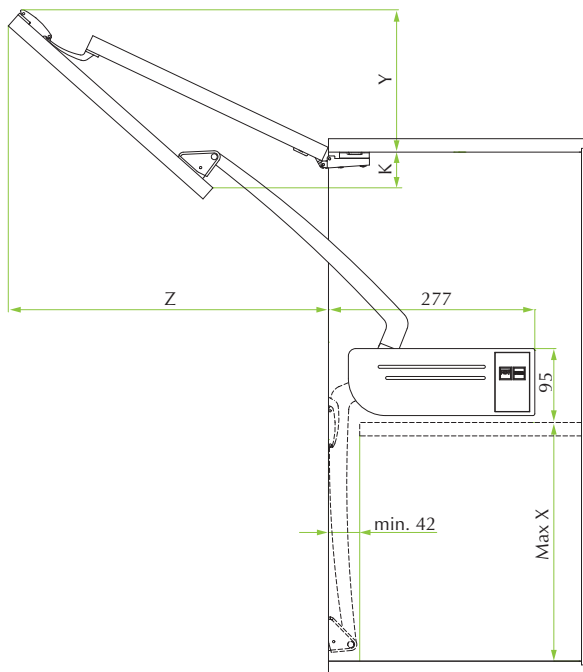

Cabinet fixing

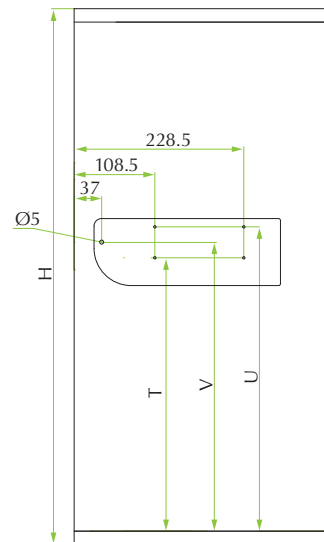

Door fixing
C = Overlay

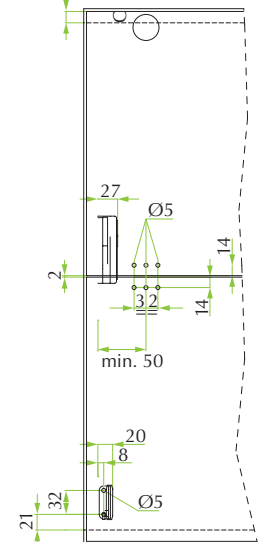

Application 110°:

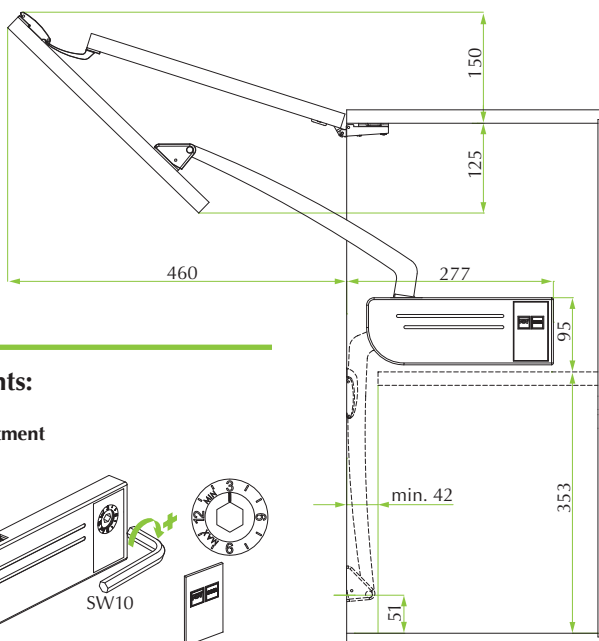

Cabinet fixing

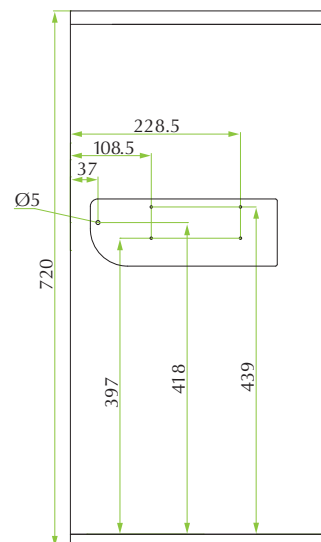

Door fixing
C = Overlay

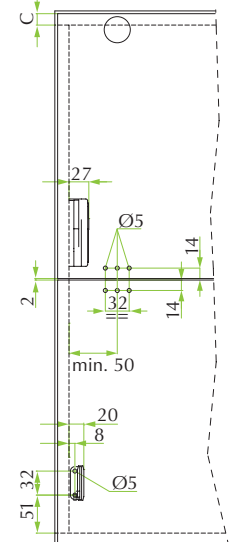

Adjustments:

Weight adjustment

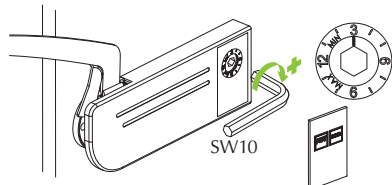



Technical specifications:

- The three in one lifter solution:
 - self holding in all positions
 - self lifting and SlowMotion
 - flap with brake
- 32mm standard cabinet drilling
- Covers 75°, 90° and 105° angles
- Combined with SlowMotion hinges, it confers a perfect movement to the door

SINGLE KIT

Code	Description		Packing
59.0VW0.05.00.00000	Kit AeroWing	hole distance 37mm	50 kits
59.0VW0.05.28.00000	Kit AeroWing	hole distance 28mm	50 kits

Packed in a kit, consists of:

- 1 joint AeroWing
- 1 bracket for cabinet
- 1 bracket for wooden door
- 1 bracket for aluminium frame
- 4 selftapping screws Ø4x15 mm
- Assembly instructions

INDUSTRIAL PACKING

Code	Description		Packing
59.0VWR.05.0000000	Joint AeroWing		50 pcs per box
59.0WBL.05.0000000	Set of brackets for cabinet and bracket for wooden door	hole distance 37mm	100 sets per box
59.0WBA.05.0000000	Set of brackets for cabinet and brackets for aluminium frame	hole distance 37mm	100 sets per box
59.0WBL.05.2800000	Set of brackets for cabinet and brackets for wooden door	hole distance 28mm	100 sets per box
59.0WBA.05.2800000	Set of brackets for cabinet and brackets for aluminium frame	hole distance 28mm	100 sets per box

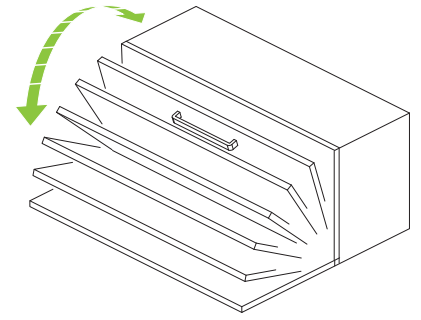
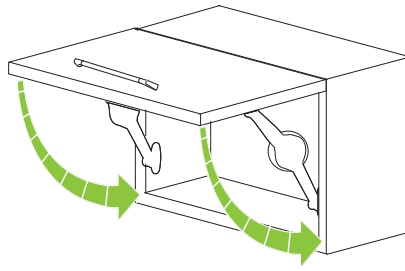
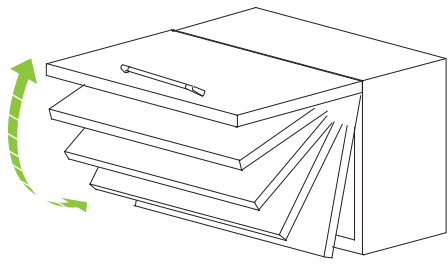

Up solution application:

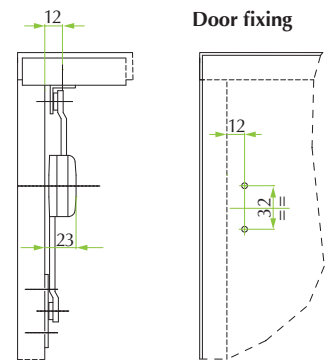
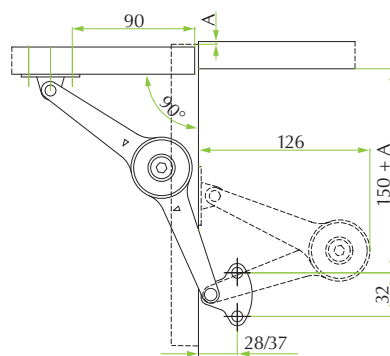
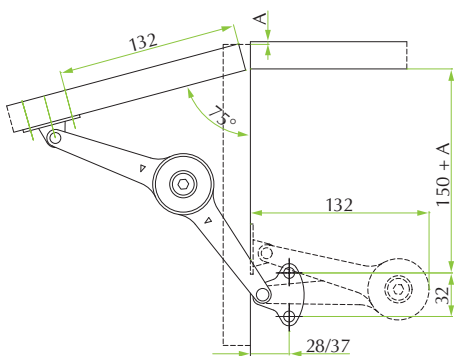

Door fixing

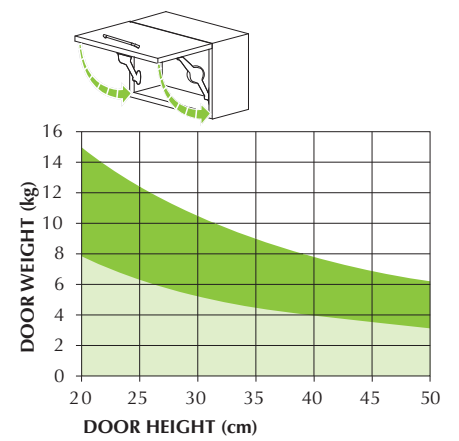
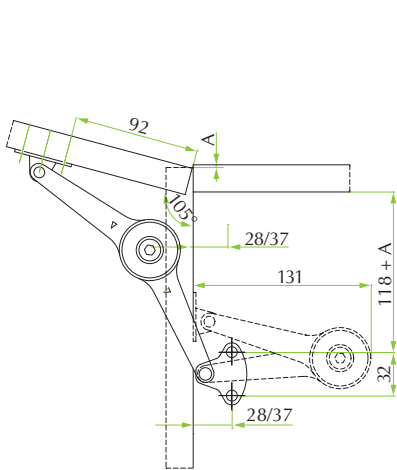

■ AeroWing x2 ■ AeroWing x1

Down solution application:

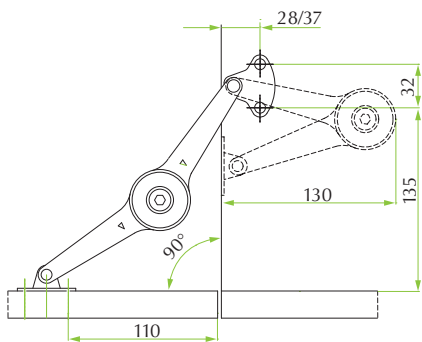

Magnet required. Not supplied.

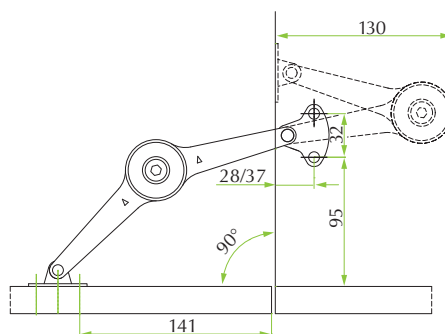

Magnet not required.



Technical specifications:

- Upwards assisted lifter
- Covers 85°, 90° and 95° angles
- 32 mm standard cabinet drilling
- Assisted opening
- Possible to combine with OneTouch mechanism for handleless application

SINGLE KIT

Code	Description	Force	Packing
59.5K10.06.040.3000	Kit AeroLift - up solution	40N	100 kits per box
59.5K10.06.060.3000	Kit AeroLift - up solution	60N	100 kits per box
59.5K10.06.080.3000	Kit AeroLift - up solution	80N	100 kits per box
59.5K10.06.100.3000	Kit AeroLift - up solution	100N	100 kits per box
59.5K10.06.120.3000	Kit AeroLift - up solution	120N	100 kits per box

Packed in a kit, consists of:

- 1 gas spring AeroLift up solution
- 1 bracket for cabinet
- 1 bracket for wooden door
- 1 bracket for aluminium frame
- 5 selftapping screws Ø3.5x15 mm
- 2 flathead selftapping screws Ø3.5x15 mm
- Assembly instructions

INDUSTRIAL PACKING

Code	Description	Force	Packing
59.5100.06.040.3010	Gas spring AeroLift - up solution	40N	1000 pcs per box
59.5100.06.060.3010	Gas spring AeroLift - up solution	60N	1000 pcs per box
59.5100.06.080.3010	Gas spring AeroLift - up solution	80N	1000 pcs per box
59.5100.06.100.3010	Gas spring AeroLift - up solution	100N	1000 pcs per box
59.5100.06.120.3010	Gas spring AeroLift - up solution	120N	1000 pcs per box
59.5ASP.05.000.00	Bracket for cabinet without dowels	–	1000 pcs per box
59.5ASP.05.000.0A	Bracket for cabinet with dowels	–	1000 pcs per box
59.5ALP.05.000.00	Bracket for wooden door	–	1000 pcs per box
59.5AAP.05.000.00	Bracket for aluminium frame	–	1000 pcs per box
59.5AAP.05.000.0A	Bracket for aluminium frame with Euro screws	–	1000 pcs per box



Bracket for cabinet



Bracket for wooden door



Bracket for door with frame

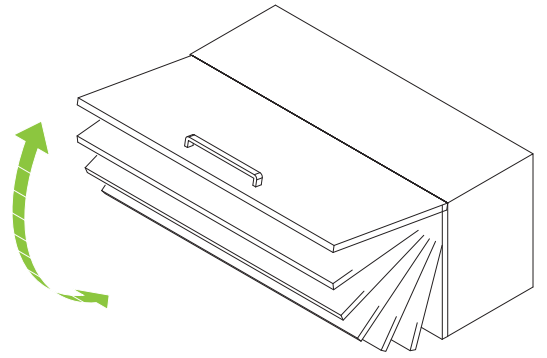

Up solution application:

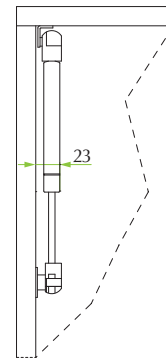
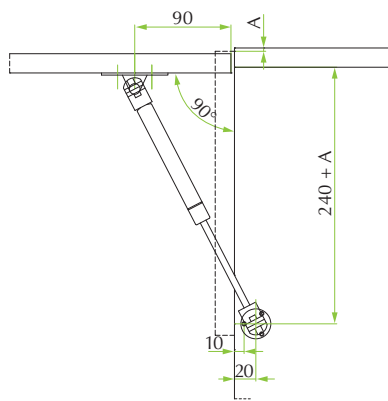
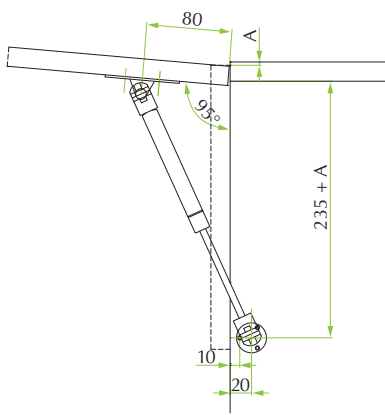

Door fixing

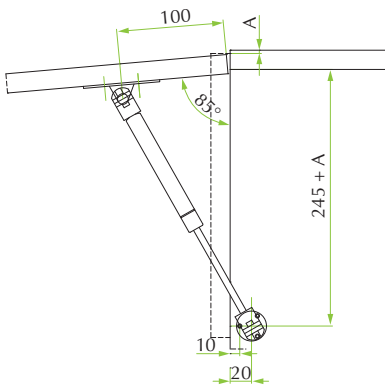
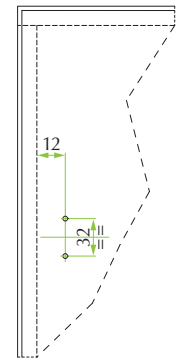

A	X	Y
<90°	100	245
90°	90	240
>90°	80	235

OneTouch application:

With magnet and push hinges

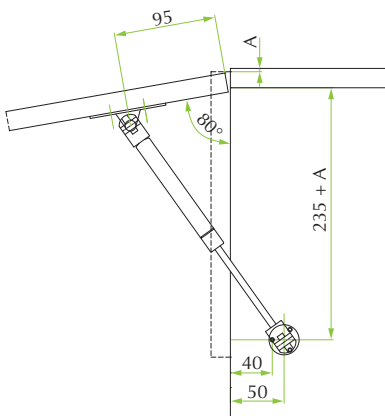

With long version and standard hinges

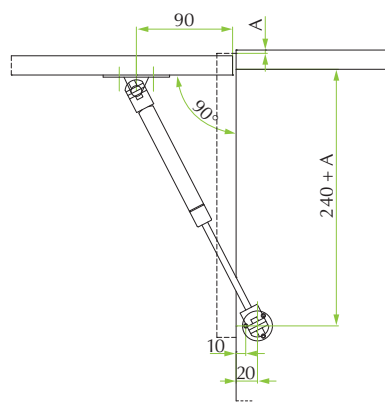

Technical details about OneTouch devices are shown from page 144 to page 147.



Technical specifications:

- Downwards assisted lifter
- Angles 90°
- 32mm standard cabinet drilling
- Assisted opening and SlowMotion closing
- Possible to combine with OneTouch mechanism for handle less application

SINGLE KIT

Code	Description	Force	Packing
59.5K20.06.060.3000	Kit AeroLift - down solution	60N	100 kits per box
59.5K20.06.080.3000	Kit AeroLift - down solution	80N	100 kits per box
59.5K20.06.100.3000	Kit AeroLift - down solution	100N	100 kits per box
59.5K20.06.120.3000	Kit AeroLift - down solution	120N	100 kits per box

Packed in a kit, consists of:

- 1 gas spring AeroLift down solution
- 1 bracket for cabinet
- 1 bracket for wooden door
- 1 bracket for aluminium frame
- 5 selftapping screws Ø3.5x15 mm
- 2 flathead selftapping screws Ø3.5x15 mm
- Assembly instructions

INDUSTRIAL PACKING

Code	Description	Force	Packing
59.5200.06.060.3010	Gas spring AeroLift - down solution	60N	1000 pcs per box
59.5200.06.080.3010	Gas spring AeroLift - down solution	80N	1000 pcs per box
59.5200.06.100.3010	Gas spring AeroLift - down solution	100N	1000 pcs per box
59.5200.06.120.3010	Gas spring AeroLift - down solution	120N	1000 pcs per box
59.5ASP.05.000.00	Bracket for cabinet without dowels	–	1000 pcs per box
59.5ASP.05.000.0A	Bracket for cabinet with dowels	–	1000 pcs per box
59.5ALP.05.000.00	Bracket for wooden door	–	1000 pcs per box
59.5AAP.05.000.00	Bracket for aluminium frame	–	1000 pcs per box
59.5AAP.05.000.0A	Bracket for aluminium frame with Euro screws	–	1000 pcs per box

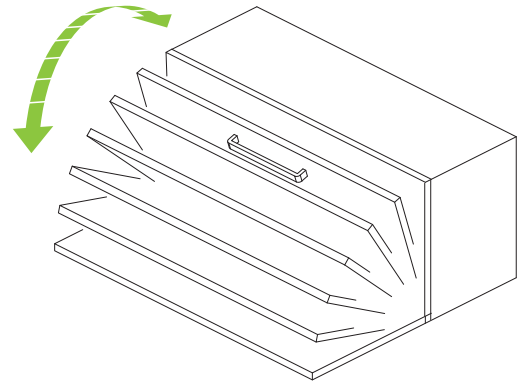

Down solution application:

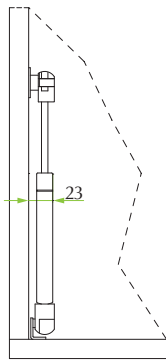
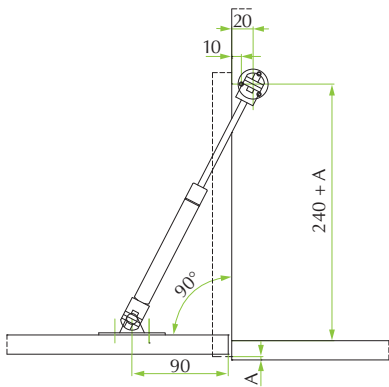

Door fixing

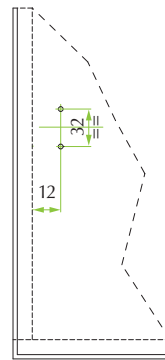

OneTouch application:

Compatible with all the FGV OneTouch devices available

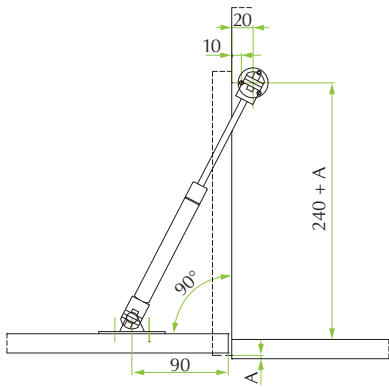

Technical details about OneTouch devices are shown from page 144 to page 147.