





Affordable drawer system

Simple, practical and economical

Largest range on the market

SlowMotion Zeta optional

Uniset drawers are used by a very large base of Kitchen and bathroom manufacturers all over the world for many years. It is the preferred solution of carpenters and cabinet makers in many countries. The reasons therefore are simple: it is the best affordable single wall quality drawer system on the market. The product is of solid make with up-to-date features, including an optional SlowMotion Zeta damping system. Uniset drawers are used from entry level kitchens to medium level applications and thanks to excellent build quality in a dedicated plant, are up to the highest quality standards.

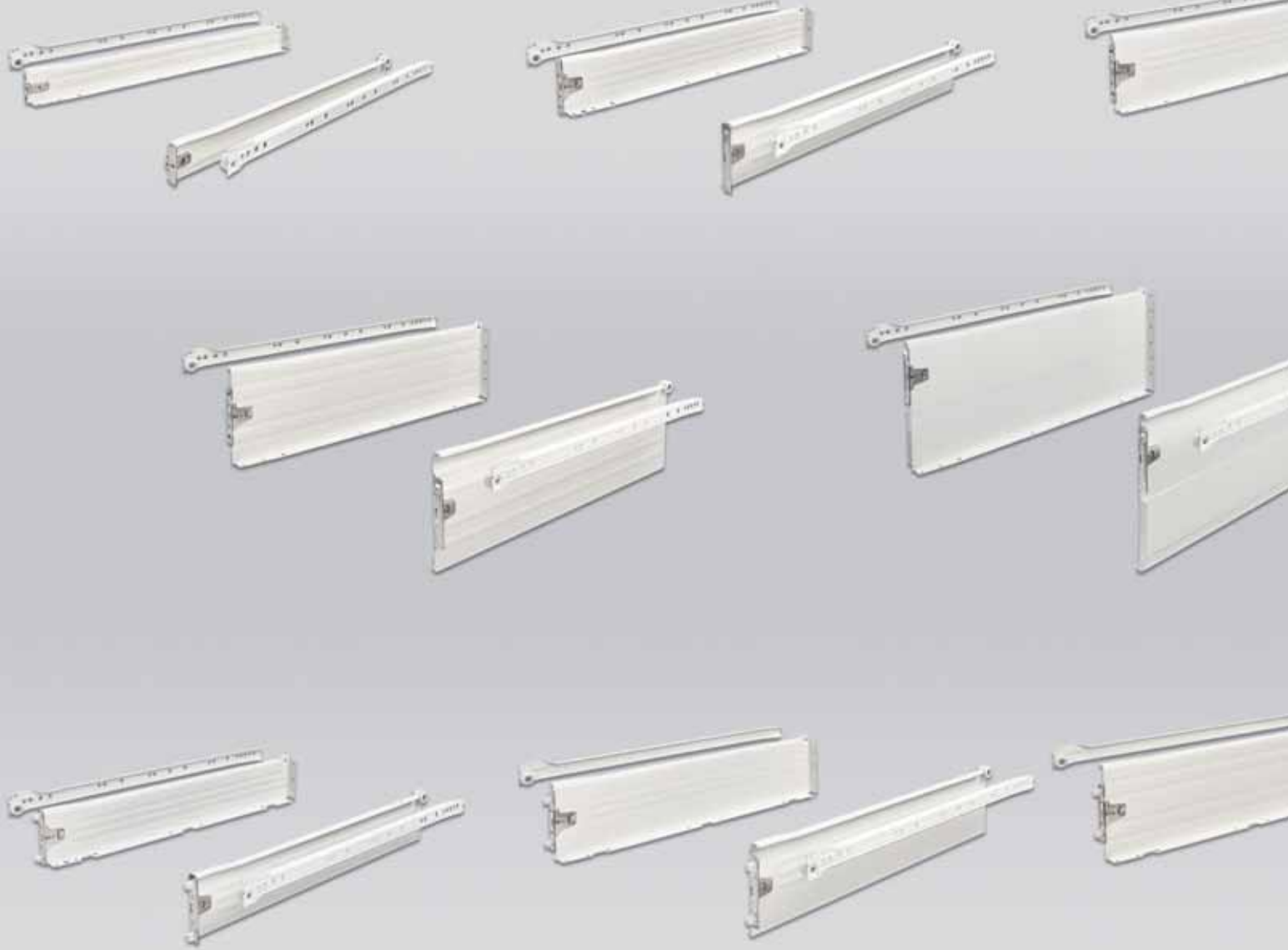

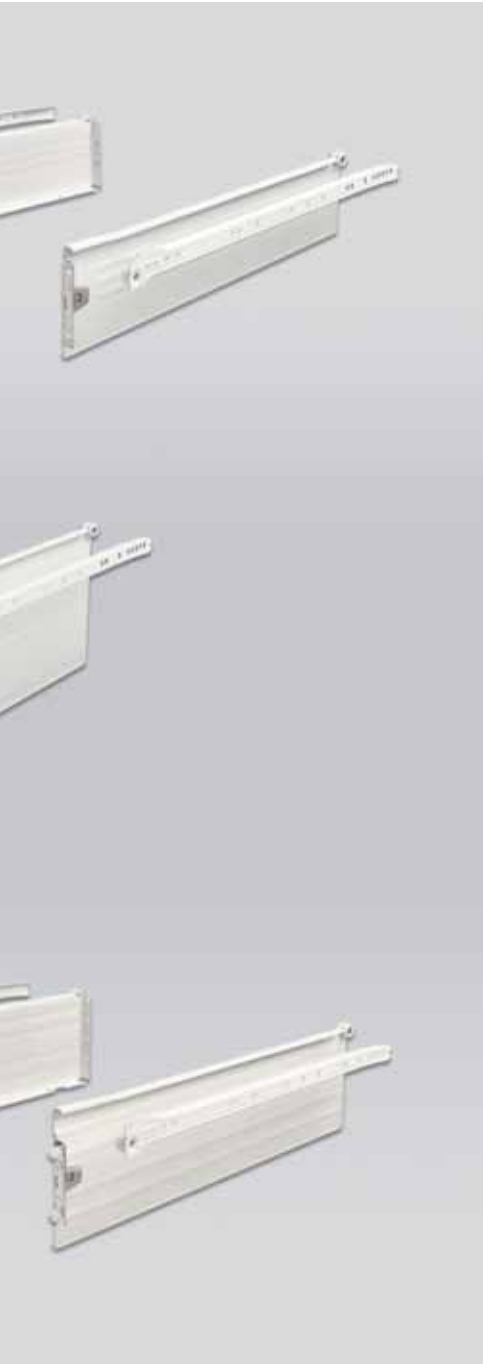

Uniset Index

<i>Common technical information</i>	<i>260-261</i>
<i>Uniset 551</i>	<i>262-263</i>
<i>Uniset 651</i>	<i>264-265</i>
<i>Uniset 751</i>	<i>266-267</i>
<i>Uniset 851</i>	<i>268-269</i>
<i>Uniset 951</i>	<i>270-271</i>
<i>Uniset 681/781/881</i>	<i>272-273</i>
<i>Back panel & back fixing</i>	<i>274-275</i>
<i>Round railing & transversal tubes</i>	<i>276-277</i>
<i>Square railing & accessories</i>	<i>278-279</i>
<i>Internal drawer</i>	<i>280-281</i>
<i>Tetrix cutlery tray for Uniset drawer</i>	<i>282-283</i>
<i>SlowMotion Zeta ANYWAY</i>	<i>284-285</i>
<i>Machines & accessories</i>	<i>286-287</i>
<i>Instruction for use</i>	<i>288-289</i>

The Uniset single wall drawer range is available in 7 depths and 5 heights with metal backs solutions or wooden backs connectors. They come as standard with 25kg dynamic load capacity and are available for screw assembly and for machine assembly. The range of colours, the program of accessories and the proposed assembly equipment are a unique offer in the market.

Common technical information

For all Uniset drawer-standard range

Uniset drawer-standard range

Uniset drawer 551 H53

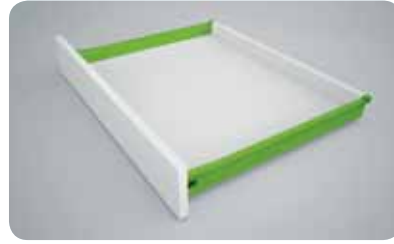

page 262-263

Uniset drawer 651 H85



page 264-265

Uniset drawer 751 H117



page 266-267

Uniset drawer 851 H150



page 268-269

Uniset drawer 951 H200



page 270-271

Slide fixing positions & drilling pattern

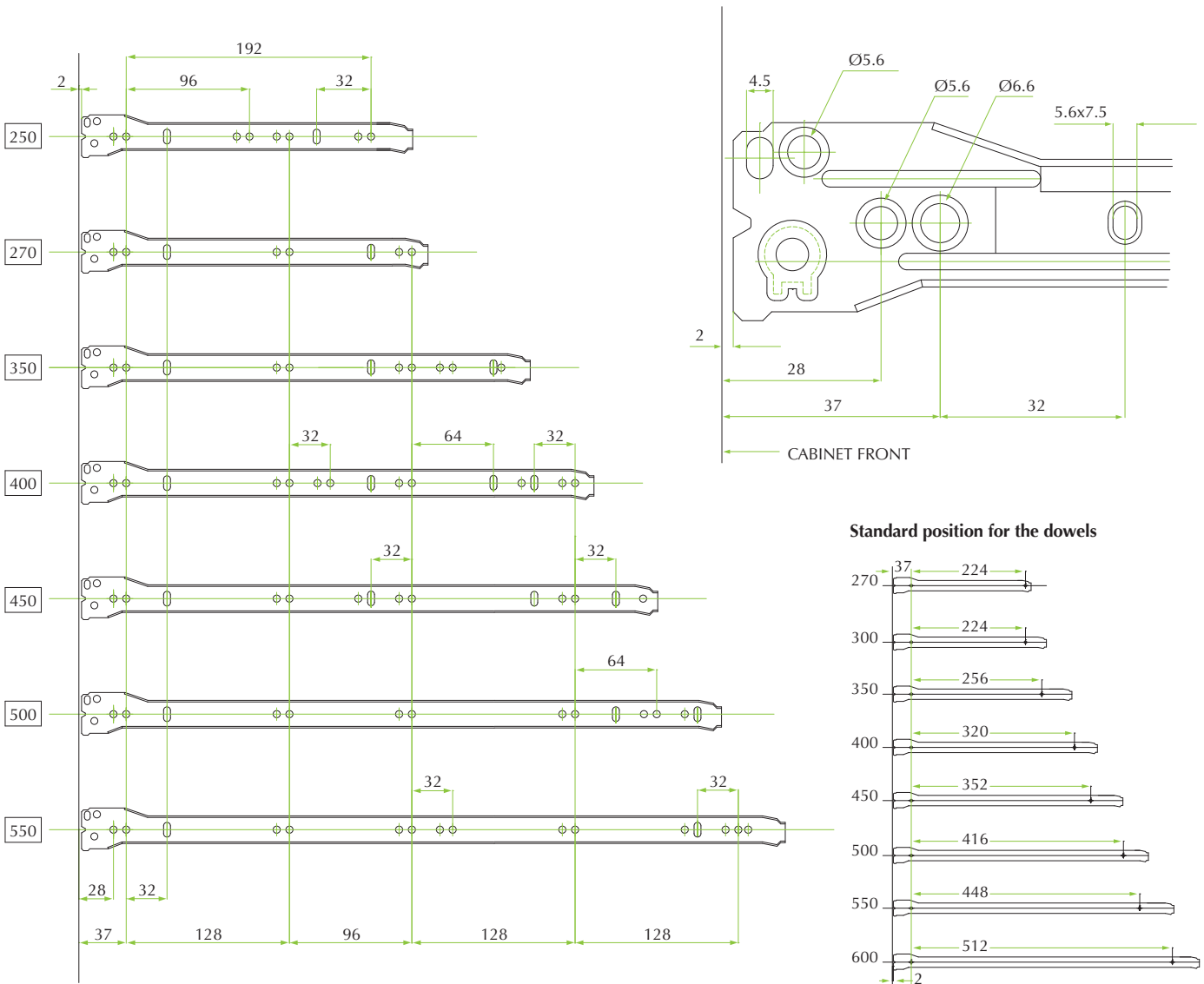

Products could have pilot holes not shown in the drawings which are not contractual

Extension loss

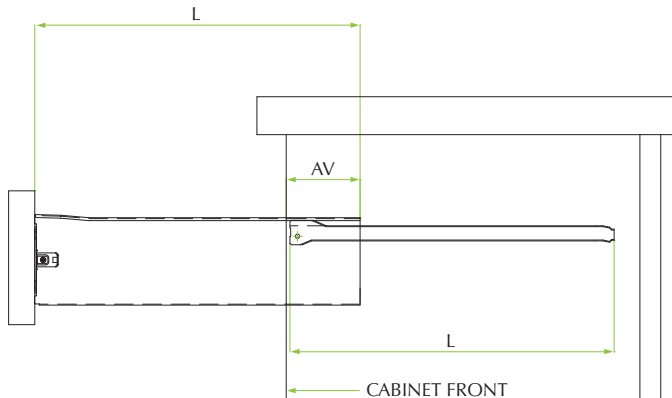

L	250	270	350	400	450	500	550
AV	75	75	75	100	100	100	120

L = NOMINAL LENGTH
AV = EXTENSION LOSS

Bottom length

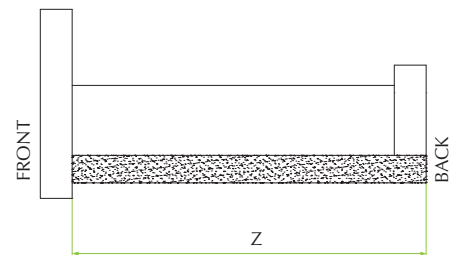

L	250	270	350	400	450	500	550
Z	248	268	348	398	448	498	548

Z = BOTTOM LENGTH

Uniset drawer 551 H53



Uniset 551 in height 53mm

Benefits for the industry

- Large range of dimensions from 250 to 550 mm depth
- Identical width for wooden bottom and back panel
- Unilateral restraint-guiding to compensate for furniture tolerances
- Simple bottom mounting for ease of assembly
- Vertical front adjustment +/-1.5mm up and down
- Lasting quality thanks to optimised materials
- Choice of colours to match furniture finish
- Excellent load ability with 25kg standard capacity throughout the range
- 551 screw fixing and 561 dowel fixing drawer versions
- NoTool application for SlowMotion Zeta Anyway

Benefits for the consumer

- Smooth functioning thanks to new generation of wheel design and epoxy finish
- Long self-closing feature for secure and controlled closing
- Small extraction loss due to compact build
- Straight inner wall for space optimisation
- Ease of drawer extraction for cleaning
- Excellent load ability with 25kg standard capacity
- Add-on SlowMotion Zeta Anyway damping with stop-close SlowMotion^{FR} technology

DRAWER 551

Screw fixing brackets

Code	Description	Packing
58.0551.C*.250.°000	Uniset drawer 551 H53 - 250	10 per box
58.0551.C*.270.°000	Uniset drawer 551 H53 - 270	10 per box
58.0551.C*.350.°000	Uniset drawer 551 H53 - 350	10 per box
58.0551.C*.400.°000	Uniset drawer 551 H53 - 400	10 per box
58.0551.C*.450.°000	Uniset drawer 551 H53 - 450	10 per box
58.0551.C*.500.°000	Uniset drawer 551 H53 - 500	10 per box
58.0551.C*.550.°000	Uniset drawer 551 H53 - 550	10 per box

* colour codes: 1 = White Ral 9010 / 6 = Grey Ral 7004 / 8 = Silver Ral 9006.
° drawer: 0 = Standard version / R = NoTool version.

10x10 Dowel fixing brackets

Code	Description	Packing
58.0561.C*.250.°000	Uniset drawer 561 H53 - 250	10 per box
58.0561.C*.270.°000	Uniset drawer 561 H53 - 270	10 per box
58.0561.C*.350.°000	Uniset drawer 561 H53 - 350	10 per box
58.0561.C*.400.°000	Uniset drawer 561 H53 - 400	10 per box
58.0561.C*.450.°000	Uniset drawer 561 H53 - 450	10 per box
58.0561.C*.500.°000	Uniset drawer 561 H53 - 500	10 per box
58.0561.C*.550.°000	Uniset drawer 561 H53 - 550	10 per box

* colour codes: 1 = White Ral 9010 / 6 = Grey Ral 7004 / 8 = Silver Ral 9006.
° drawer: 0 = Standard version / R = NoTool version.



Uniset R NoTool version for SlowMotion Zeta application



Uniset drawer grey finish

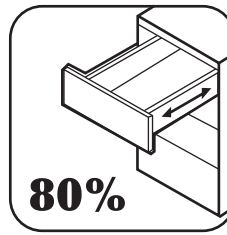

Fixing dimensions

DRAWER 551

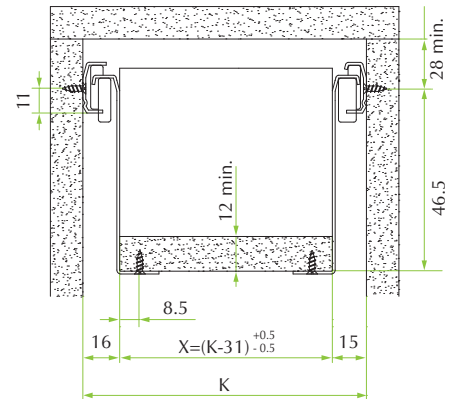
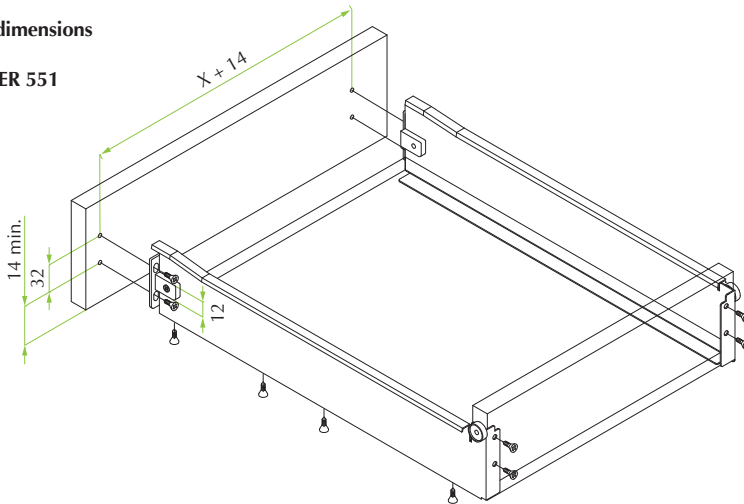

Front & back drilling pattern

X = BOTTOM WIDTH
Y = BACK WIDTH
K = INTERNAL CABINET WIDTH

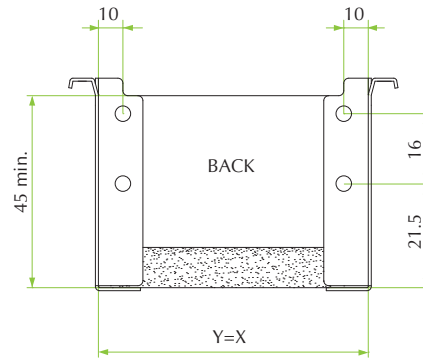
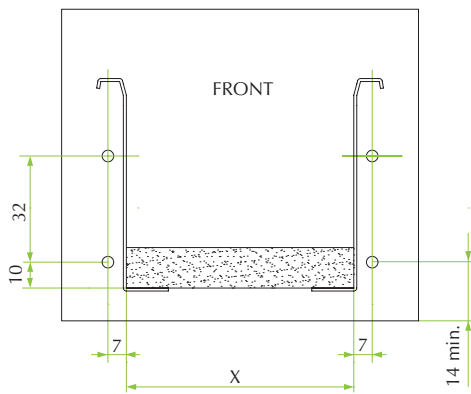

Adjustments

+1.5
-1.5

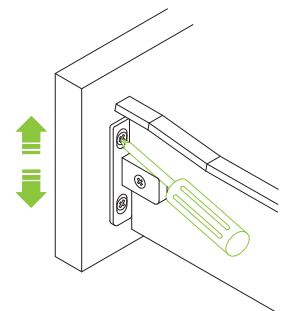

Uniset R NoTool version for SlowMotion Zeta application

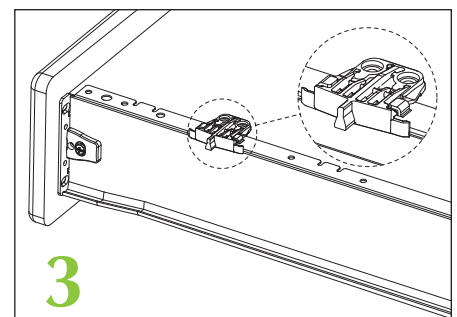
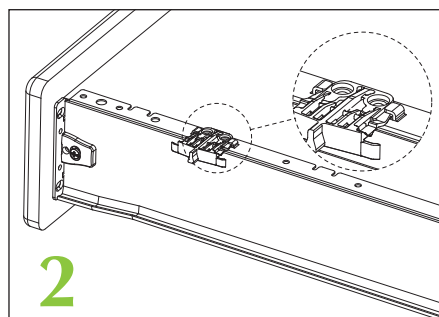
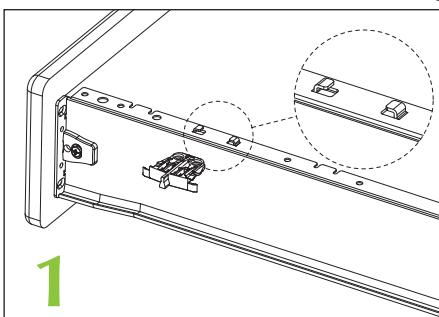

Values given in mm

263

Uniset drawer 651 H85



Uniset 651 in height 85mm

Benefits for the industry

- Large range of dimensions from 250 to 550 mm depth
- Identical width for wooden bottom and back panel
- Unilateral restraint-guiding to compensate for furniture tolerances
- Simple bottom mounting for ease of assembly
- Strong front fix with 64mm spacing
- Vertical front adjustment +/-1.5mm up and down
- Horizontal front adjustment +/-1.5mm left and right
- Lasting quality thanks to optimised materials
- Choice of colours to match furniture finish
- Excellent load ability with 25kg standard capacity throughout the range
- 651 screw fixing and 661 dowel fixing drawer versions
- NoTool application for SlowMotion Zeta Anyway
- Available also machine compatible crimp on version 681 (page 272-273)

Benefits for the consumer

- Smooth functioning thanks to new generation of wheel design and epoxy finish
- Long self-closing feature for secure and controlled closing
- Small extraction loss due to compact build
- Straight inner wall for space optimisation
- Ease of drawer extraction for cleaning
- Excellent load ability with 25kg standard capacity
- Add-on SlowMotion Zeta Anyway damping with stop-close SlowMotion^{FR} technology

DRAWER 651

Screw fixing brackets

Code	Description	Packing
58.065 [^] .C*.25G.°000	Uniset drawer 651 H85 - 250	10 per box
58.065 [^] .C*.27G.°000	Uniset drawer 651 H85 - 270	10 per box
58.065 [^] .C*.35G.°000	Uniset drawer 651 H85 - 350	10 per box
58.065 [^] .C*.40G.°000	Uniset drawer 651 H85 - 400	10 per box
58.065 [^] .C*.45G.°000	Uniset drawer 651 H85 - 450	10 per box
58.065 [^] .C*.50G.°000	Uniset drawer 651 H85 - 500	10 per box
58.065 [^] .C*.55G.°000	Uniset drawer 651 H85 - 550	10 per box

[^] brackets: 1 = with premounted brackets / 0 = with unassembled brackets.
 * colour codes: 1 = White Ral 9010 / 6 = Grey Ral 7004 / 8 = Silver Ral 9006.
 ° drawer: 0 = Standard version / R = NoTool version.

10x10 Dowel fixing brackets

Code	Description	Packing
58.066 [^] .C*.25G.°000	Uniset drawer 661 H85 - 250	10 per box
58.066 [^] .C*.27G.°000	Uniset drawer 661 H85 - 270	10 per box
58.066 [^] .C*.35G.°000	Uniset drawer 661 H85 - 350	10 per box
58.066 [^] .C*.40G.°000	Uniset drawer 661 H85 - 400	10 per box
58.066 [^] .C*.45G.°000	Uniset drawer 661 H85 - 450	10 per box
58.066 [^] .C*.50G.°000	Uniset drawer 661 H85 - 500	10 per box
58.066 [^] .C*.55G.°000	Uniset drawer 661 H85 - 550	10 per box

[^] brackets: 1 = with premounted brackets / 0 = with unassembled brackets.
 * colour codes: 1 = White Ral 9010 / 6 = Grey Ral 7004 / 8 = Silver Ral 9006.
 ° drawer: 0 = Standard version / R = NoTool version.



Uniset R NoTool version for SlowMotion Zeta application



Uniset drawer 651 grey finish

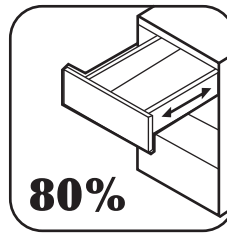

Fixing dimensions

DRAWER 651

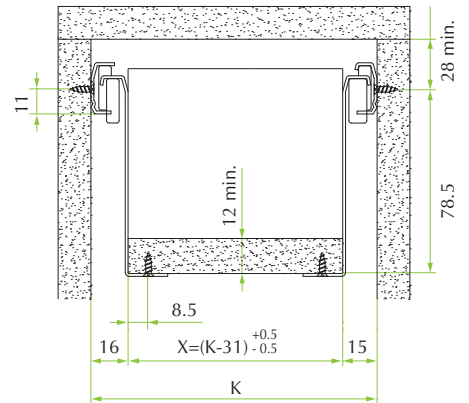
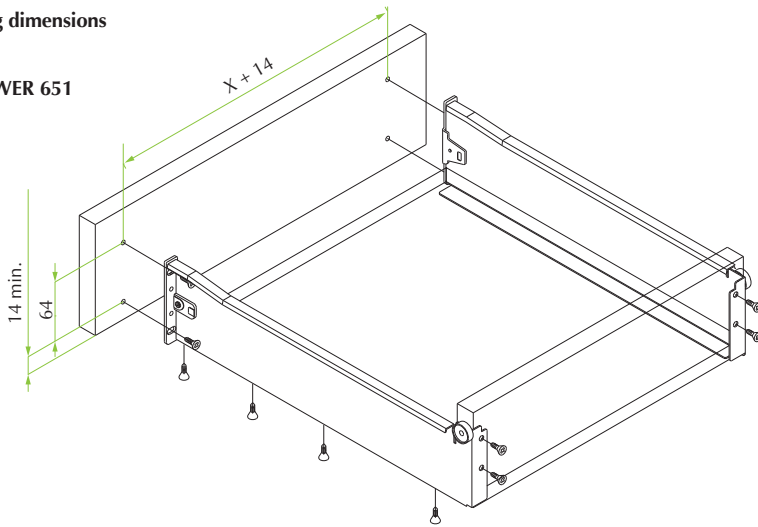

Front & back drilling pattern

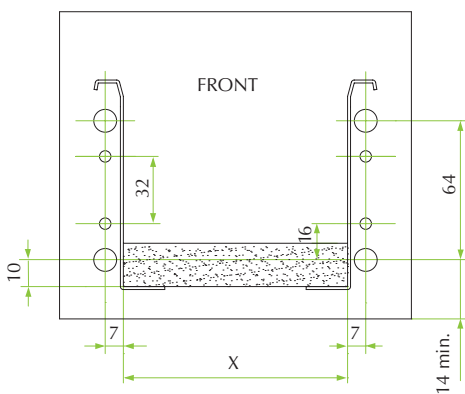

X = BOTTOM WIDTH
Y = BACK WIDTH
K = INTERNAL CABINET WIDTH

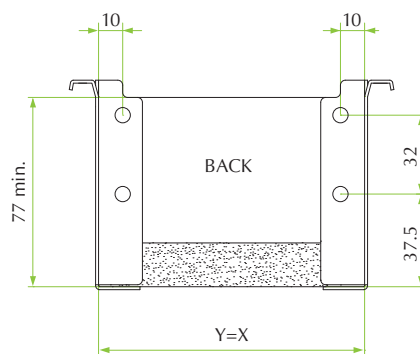

Adjustments

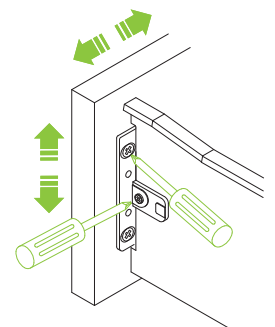

Uniset R NoTool version for SlowMotion Zeta application

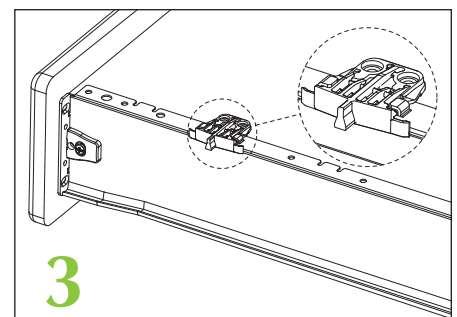
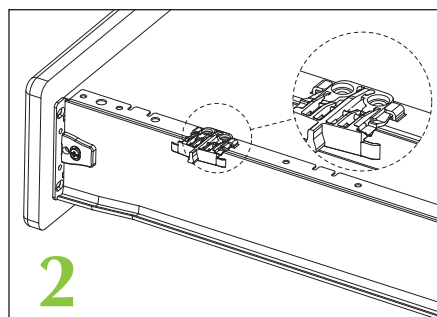
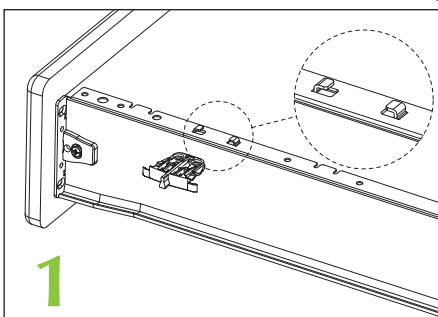

Uniset drawer 751 H117



Uniset 751 in height 117mm

Benefits for the industry

- Large range of dimensions from 250 to 550 mm depth
- Identical width for wooden bottom and back panel
- Unilateral restraint-guiding to compensate for furniture tolerances
- Simple bottom mounting for ease of assembly
- Strong front fix with 64mm spacing
- Vertical front adjustment +/-1.5mm up and down
- Horizontal front adjustment +/- 1.5mm left and right
- Lasting quality thanks to optimised materials
- Choice of colours to match furniture finish
- Excellent load ability with 25kg standard capacity throughout the range
- 751 screw fixing and 761 dowel fixing drawer versions
- NoTool application for SlowMotion Zeta Anyway
- Available also machine compatible crimp on version 781 (page 272-273)

Benefits for the consumer

- Smooth functioning thanks to new generation of wheel design and epoxy finish
- Long self-closing feature for secure and controlled closing
- Small extraction loss due to compact build
- Straight inner wall for space optimisation
- Ease of drawer extraction for cleaning
- Excellent load ability with 25kg standard capacity
- Add-on SlowMotion Zeta Anyway damping with stop-close SlowMotion^{FR} technology

DRAWER 751

Screw fixing brackets

Code	Description	Packing
58.075 [^] .C*.25G.°000	Uniset drawer 751 H117 - 250	10 per box
58.075 [^] .C*.27G.°000	Uniset drawer 751 H117 - 270	10 per box
58.075 [^] .C*.35G.°000	Uniset drawer 751 H117 - 350	10 per box
58.075 [^] .C*.40G.°000	Uniset drawer 751 H117 - 400	10 per box
58.075 [^] .C*.45G.°000	Uniset drawer 751 H117 - 450	10 per box
58.075 [^] .C*.50G.°000	Uniset drawer 751 H117 - 500	10 per box
58.075 [^] .C*.55G.°000	Uniset drawer 751 H117 - 550	10 per box

[^] brackets: 1 = with premounted brackets / 0 = with unassembled brackets.
 * colour codes: 1 = White Ral 9010 / 6 = Grey Ral 7004 / 8 = Silver Ral 9006.
 ° drawer: 0 = Standard version / R = NoTool version.

10x10 Dowel fixing brackets

Code	Description	Packing
58.076 [^] .C*.25G.°000	Uniset drawer 761 H117 - 250	10 per box
58.076 [^] .C*.27G.°000	Uniset drawer 761 H117 - 270	10 per box
58.076 [^] .C*.35G.°000	Uniset drawer 761 H117 - 350	10 per box
58.076 [^] .C*.40G.°000	Uniset drawer 761 H117 - 400	10 per box
58.076 [^] .C*.45G.°000	Uniset drawer 761 H117 - 450	10 per box
58.076 [^] .C*.50G.°000	Uniset drawer 761 H117 - 500	10 per box
58.076 [^] .C*.55G.°000	Uniset drawer 761 H117 - 550	10 per box

[^] brackets: 1 = with premounted brackets / 0 = with unassembled brackets.
 * colour codes: 1 = White Ral 9010 / 6 = Grey Ral 7004 / 8 = Silver Ral 9006.
 ° drawer: 0 = Standard version / R = NoTool version.



Uniset R NoTool version for SlowMotion Zeta application



Uniset drawer grey finish

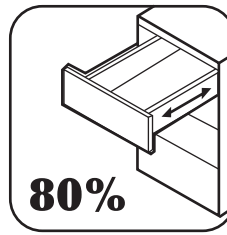

Fixing dimensions

DRAWER 751

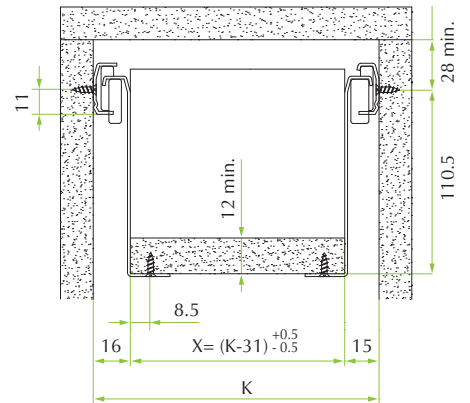
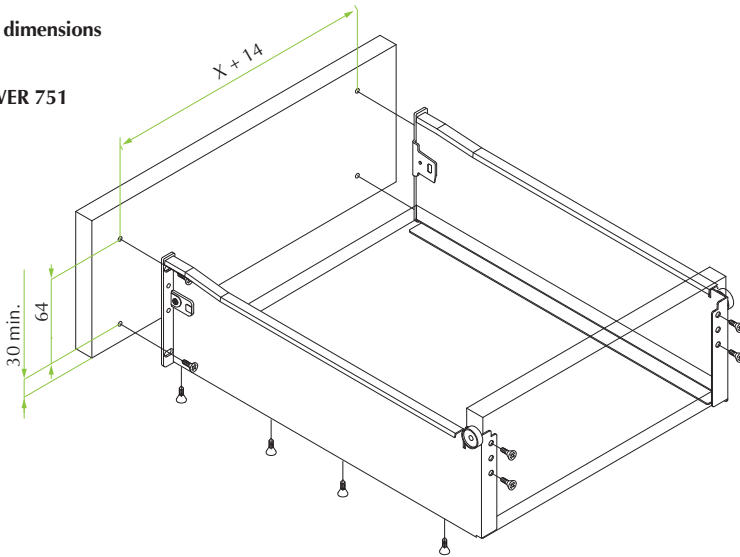

Front & back drilling pattern

X = BOTTOM WIDTH
Y = BACK WIDTH
K = INTERNAL CABINET WIDTH

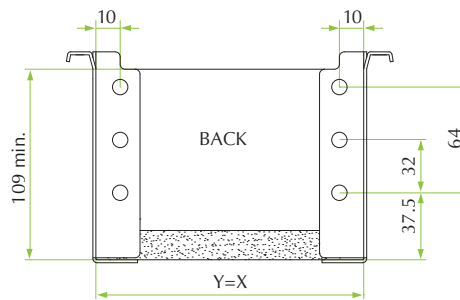
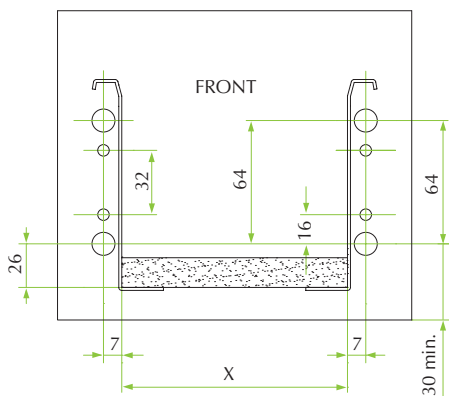

Adjustments

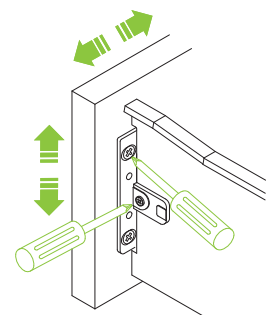

Uniset R NoTool version for SlowMotion Zeta application

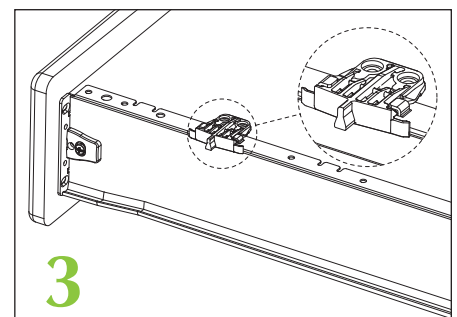
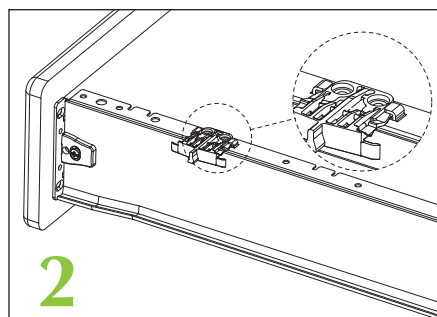
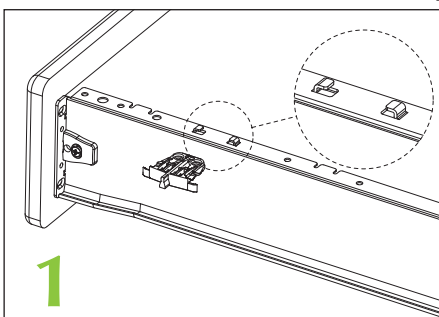

Uniset drawer 851 H150



Uniset 851 in height 150mm

Benefits for the industry

- Large range of dimensions from 250 to 550 mm depth
- Identical width for wooden bottom and back panel
- Unilateral restraint-guiding to compensate for furniture tolerances
- Simple bottom mounting for ease of assembly
- Strong front fix with 64mm spacing
- Vertical front adjustment +/-1.5mm up and down
- Horizontal front adjustment +/-1.5mm left and right
- Lasting quality thanks to optimised materials
- Choice of colours to match furniture finish
- Excellent load ability with 25kg standard capacity throughout the range
- 851 screw fixing and 861 dowel fixing drawer versions
- NoTool application for SlowMotion Zeta Anyway
- Available also machine compatible crimp on version 881 (page 272-273)

Benefits for the consumer

- Smooth functioning thanks to new generation of wheel design and epoxy finish
- Long self-closing feature for secure and controlled closing
- Small extraction loss due to compact build
- Straight inner wall for space optimisation
- Ease of drawer extraction for cleaning
- Excellent load ability with 25kg standard capacity
- Add-on SlowMotion Zeta Anyway damping with stop-close SlowMotion^{FR} technology

DRAWER 851

Screw fixing brackets

Code	Description	Packing
58.085 [^] .C*.25G.°000	Uniset drawer 851 H150 - 250	10 per box
58.085 [^] .C*.27G.°000	Uniset drawer 851 H150 - 270	10 per box
58.085 [^] .C*.35G.°000	Uniset drawer 851 H150 - 350	10 per box
58.085 [^] .C*.40G.°000	Uniset drawer 851 H150 - 400	10 per box
58.085 [^] .C*.45G.°000	Uniset drawer 851 H150 - 450	10 per box
58.085 [^] .C*.50G.°000	Uniset drawer 851 H150 - 500	10 per box
58.085 [^] .C*.55G.°000	Uniset drawer 851 H150 - 550	10 per box

[^] brackets: 1 = with premounted brackets / 0 = with unassembled brackets.

* colour codes: 1 = White Ral 9010 / 6 = Grey Ral 7004 / 8 = Silver Ral 9006.

° drawer: 0 = Standard version / R = NoTool version.

10x10 Dowel fixing brackets

Code	Description	Packing
58.086 [^] .C*.25G.°000	Uniset drawer 861 H150 - 250	10 per box
58.086 [^] .C*.27G.°000	Uniset drawer 861 H150 - 270	10 per box
58.086 [^] .C*.35G.°000	Uniset drawer 861 H150 - 350	10 per box
58.086 [^] .C*.40G.°000	Uniset drawer 861 H150 - 400	10 per box
58.086 [^] .C*.45G.°000	Uniset drawer 861 H150 - 450	10 per box
58.086 [^] .C*.50G.°000	Uniset drawer 861 H150 - 500	10 per box
58.086 [^] .C*.55G.°000	Uniset drawer 851 H150 - 550	10 per box

[^] brackets: 1 = with premounted brackets / 0 = with unassembled brackets.

* colour codes: 1 = White Ral 9010 / 6 = Grey Ral 7004 / 8 = Silver Ral 9006.

° drawer: 0 = Standard version / R = NoTool version.



Uniset R NoTool version for SlowMotion Zeta application

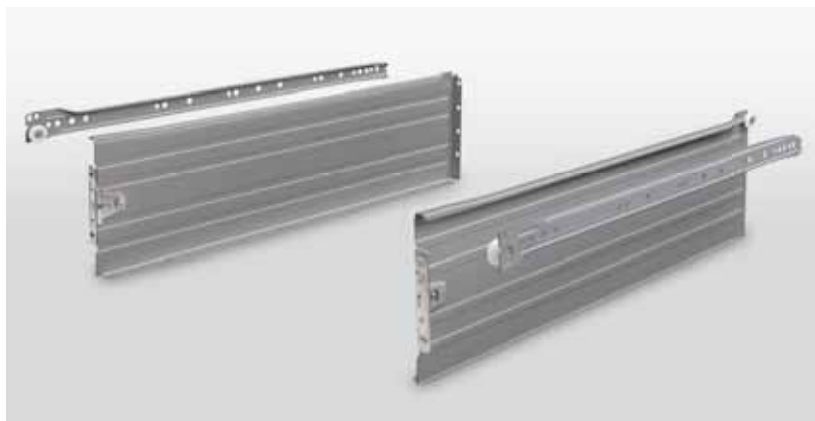

Uniset drawer grey finish

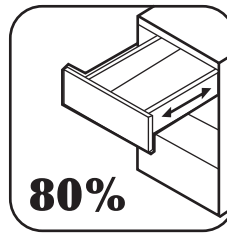

Fixing dimensions

DRAWER 851

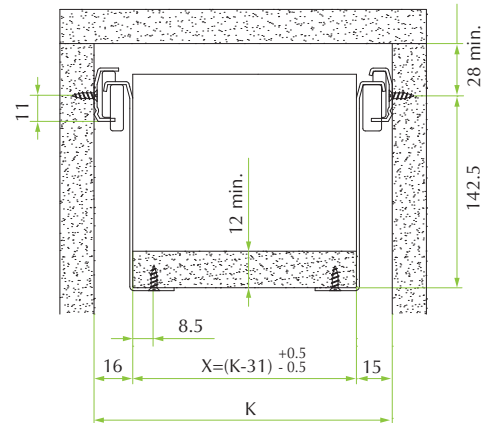
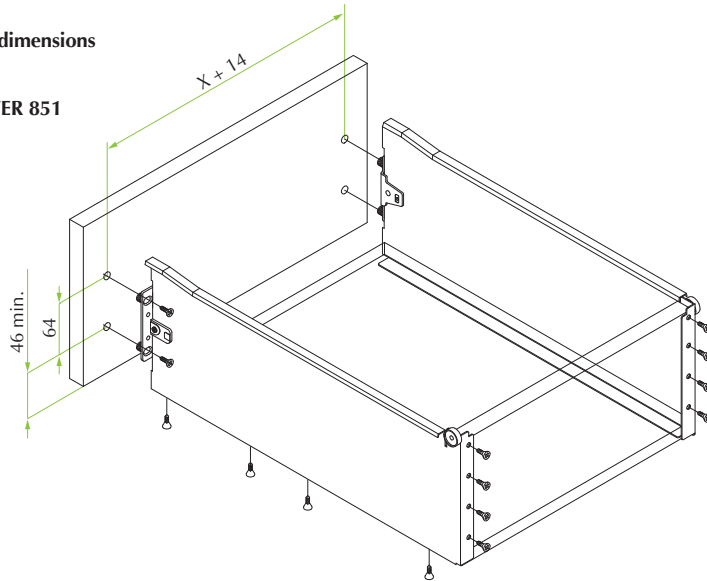

Front & back drilling pattern

X = BOTTOM WIDTH
Y = BACK WIDTH
K = INTERNAL CABINET WIDTH

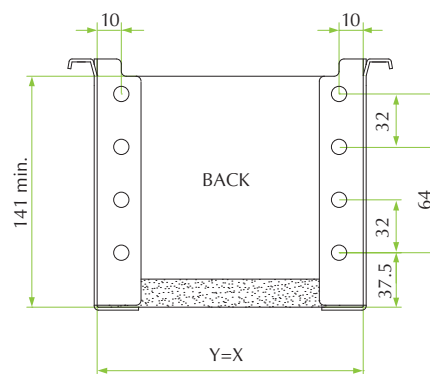
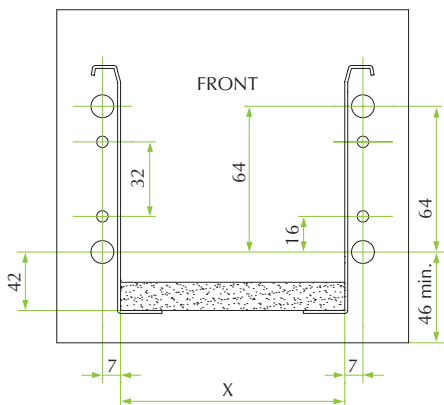

Adjustments

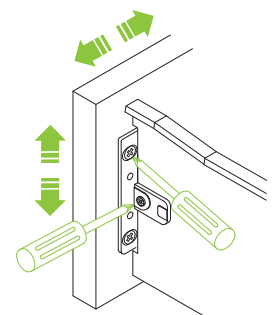

Uniset R NoTool version for SlowMotion Zeta application

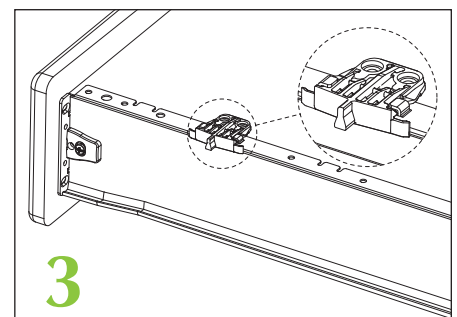
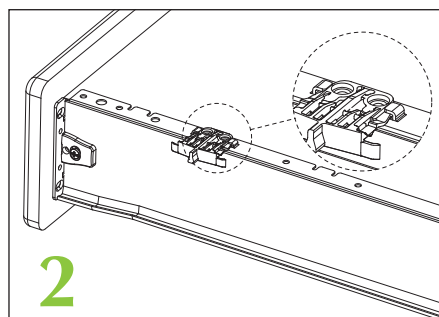
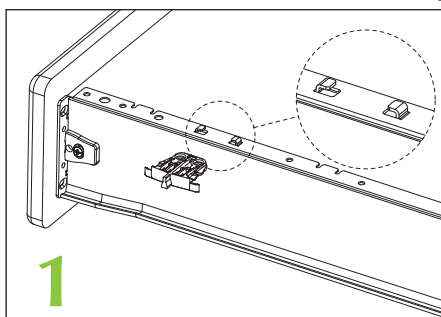

Uniset drawer 951 H200



Uniset 951 in height 200mm

Benefits for the industry

- Large range of dimensions from 250 to 550 mm depth
- Identical width for wooden bottom and back panel
- Unilateral restraint-guiding to compensate for furniture tolerances
- Simple bottom mounting for ease of assembly
- Strong front fix with 64mm spacing
- Vertical front adjustment +/-1.5mm up and down
- Horizontal front adjustment +/-1.5mm left and right
- Lasting quality thanks to optimised materials
- Choice of colours to match furniture finish
- Excellent load ability with 25kg standard capacity throughout the range

Benefits for the consumer

- Smooth functioning thanks to new generation of wheel design and epoxy finish
- Long self-closing feature for secure and controlled closing
- Small extraction loss due to compact build
- Straight inner wall for space optimisation
- Ease of drawer extraction for cleaning
- Excellent load ability with 25kg standard capacity

DRAWER 951

Screw fixing brackets

Code	Description	Packing
58.095^*.C*.25G.°000	Uniset drawer 951 H200 - 250	5 per box
58.095^*.C*.27G.°000	Uniset drawer 951 H200 - 270	5 per box
58.095^*.C*.35G.°000	Uniset drawer 951 H200 - 350	5 per box
58.095^*.C*.40G.°000	Uniset drawer 951 H200 - 400	5 per box
58.095^*.C*.45G.°000	Uniset drawer 951 H200 - 450	5 per box
58.095^*.C*.50G.°000	Uniset drawer 951 H200 - 500	5 per box
58.095^*.C*.55G.°000	Uniset drawer 951 H200 - 550	5 per box

^ brackets: 1 = with premounted brackets / 0 = with unassembled brackets.

* colour codes: 1 = White Ral 9010 / 6 = Grey Ral 7004 / 8 = Silver Ral 9006.

° drawer: 0 = Standard version / R = NoTool version.

10x10 Dowel fixing brackets

Code	Description	Packing
58.096^*.C*.25G.°000	Uniset drawer 961 H200 - 250	5 per box
58.096^*.C*.27G.°000	Uniset drawer 961 H200 - 270	5 per box
58.096^*.C*.35G.°000	Uniset drawer 961 H200 - 350	5 per box
58.096^*.C*.40G.°000	Uniset drawer 961 H200 - 400	5 per box
58.096^*.C*.45G.°000	Uniset drawer 961 H200 - 450	5 per box
58.096^*.C*.50G.°000	Uniset drawer 961 H200 - 500	5 per box
58.096^*.C*.55G.°000	Uniset drawer 961 H200 - 550	5 per box

^ brackets: 1 = with premounted brackets / 0 = with unassembled brackets.

* colour codes: 1 = white Ral 9010 / 6 = grey Ral 7004 / 8 = silver Ral 9006.

° drawer: 0 = Standard version / R = NoTool version.



Uniset R NoTool version for SlowMotion Zeta application



Uniset drawer 951 H200 grey finish

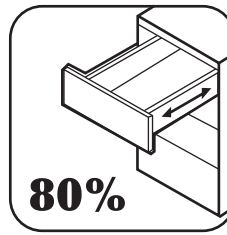

Fixing dimensions

DRAWER 951

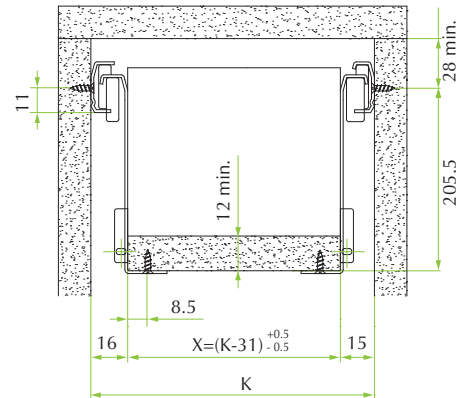
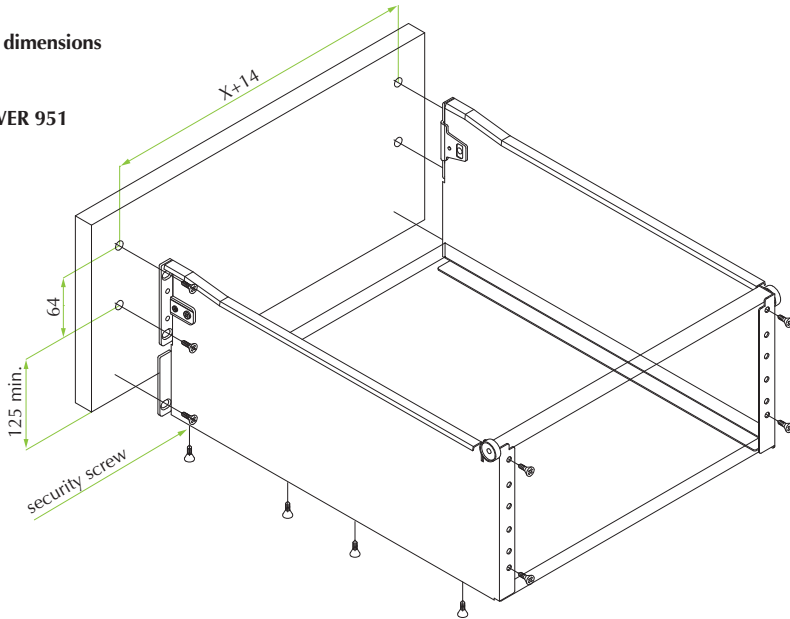

Front & back drilling pattern

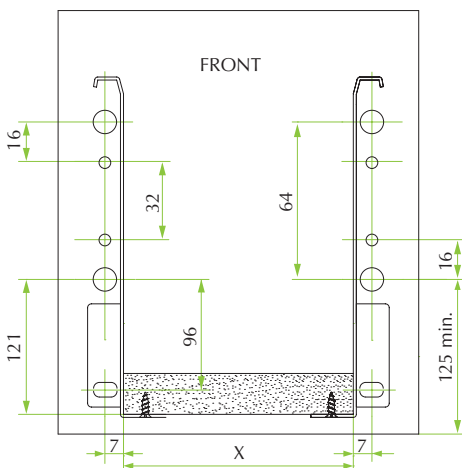

X = BOTTOM WIDTH
Y = BACK WIDTH
K = INTERNAL CABINET WIDTH

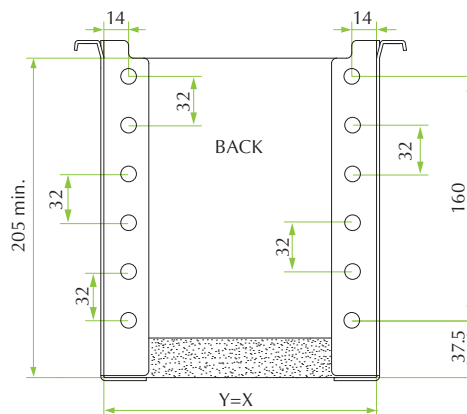

Adjustments

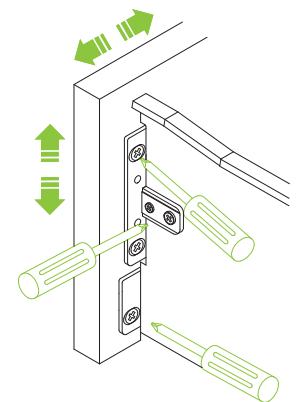

Uniset R NoTool version for SlowMotion Zeta application

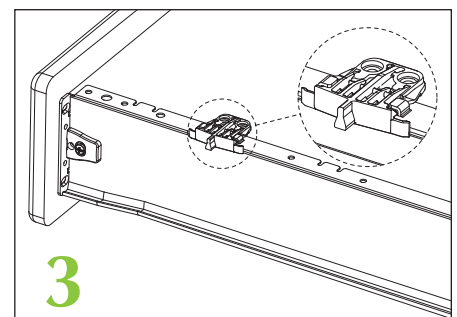
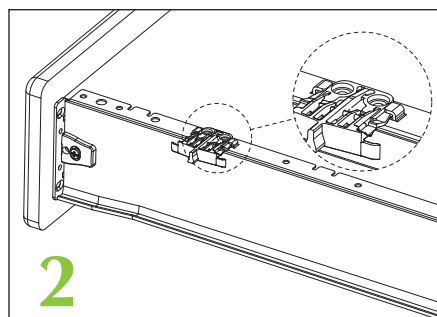
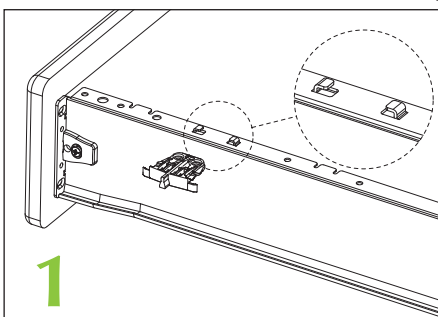

Uniset drawer 681/781/881



Uniset drawer 681 / 781 / 881 machine version

Benefits for the industry

- Uniset drawer equipped with clips on the drawer members for assembling with machine (page 286-287)
- Optimal solution for high volume production
- Easy and quick one-step drawer assembling, frontal panel included
- Available version for metal or wooden back panel
- Needed wooden bottom panel with groove

DRAWER 681 - H85

Machine version (MAC 3) - Dowel fixing brackets

Code	Description	Packing
58.0681.C*.25G.0000	Uniset drawer 681 H85 - 250	10 per box
58.0681.C*.27G.0000	Uniset drawer 681 H85 - 270	10 per box
58.0681.C*.35G.0000	Uniset drawer 681 H85 - 350	10 per box
58.0681.C*.40G.0000	Uniset drawer 681 H85 - 400	10 per box
58.0681.C*.45G.0000	Uniset drawer 681 H85 - 450	10 per box
58.0681.C*.50G.0000	Uniset drawer 681 H85 - 500	10 per box
58.0681.C*.55G.0000	Uniset drawer 681 H85 - 550	10 per box

* colour codes: 1 = White Ral 9010 / 6 = Grey Ral 7004 / 8 = Silver Ral 9006.

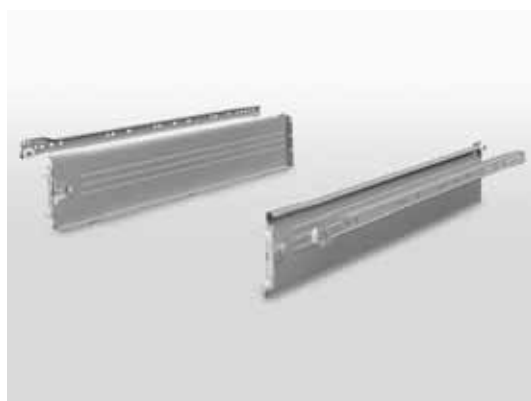

Uniset drawer 781 grey finish

DRAWER 781 - H117

Machine version (MAC 3) - Dowel fixing brackets

Code	Description	Packing
58.0781.C*.25G.0000	Uniset drawer 781 H117 - 250	10 per box
58.0781.C*.27G.0000	Uniset drawer 781 H117 - 270	10 per box
58.0781.C*.35G.0000	Uniset drawer 781 H117 - 350	10 per box
58.0781.C*.40G.0000	Uniset drawer 781 H117 - 400	10 per box
58.0781.C*.45G.0000	Uniset drawer 781 H117 - 450	10 per box
58.0781.C*.50G.0000	Uniset drawer 781 H117 - 500	10 per box
58.0781.C*.55G.0000	Uniset drawer 781 H117 - 550	10 per box

* colour codes: 1 = White Ral 9010 / 6 = Grey Ral 7004 / 8 = Silver Ral 9006.



Uniset drawer 881 grey finish

DRAWER 881 - H150

Machine version (MAC 3) - Dowel fixing brackets

Code	Description	Packing
58.0881.C*.25G.0000	Uniset drawer 881 H150 - 250	10 per box
58.0881.C*.27G.0000	Uniset drawer 881 H150 - 270	10 per box
58.0881.C*.35G.0000	Uniset drawer 881 H150 - 350	10 per box
58.0881.C*.40G.0000	Uniset drawer 881 H150 - 400	10 per box
58.0881.C*.45G.0000	Uniset drawer 881 H150 - 450	10 per box
58.0881.C*.50G.0000	Uniset drawer 881 H150 - 500	10 per box
58.0881.C*.55G.0000	Uniset drawer 881 H150 - 550	10 per box

* colour codes: 1 = White Ral 9010 / 6 = Grey Ral 7004 / 8 = Silver Ral 9006.

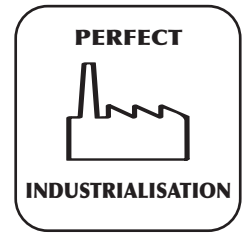
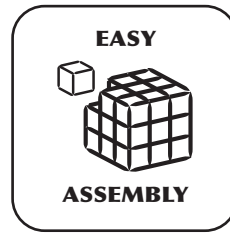
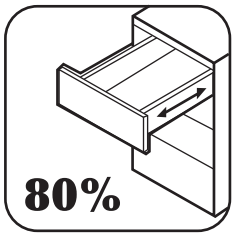

Fixing dimensions

DRAWER 681 - H85

Machine version (MAC 3) - Dowel fixing brackets

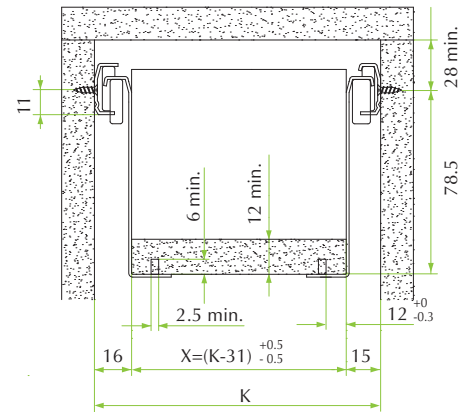
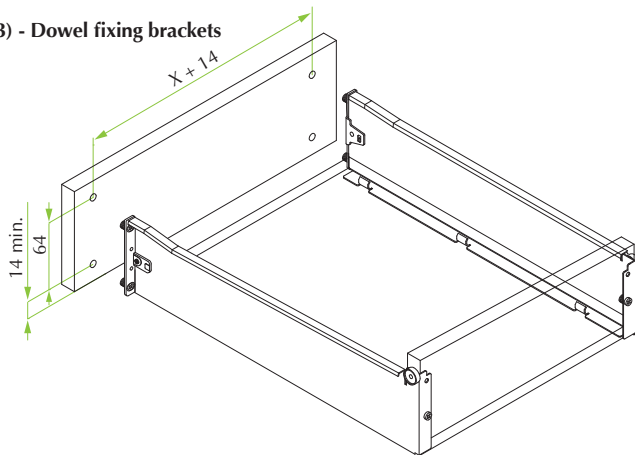

DRAWER 781 - H117

Machine version (MAC 3) - Dowel fixing brackets

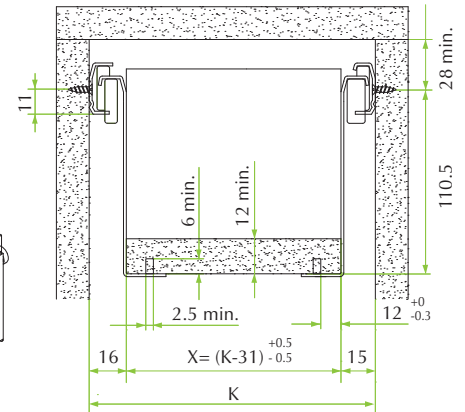
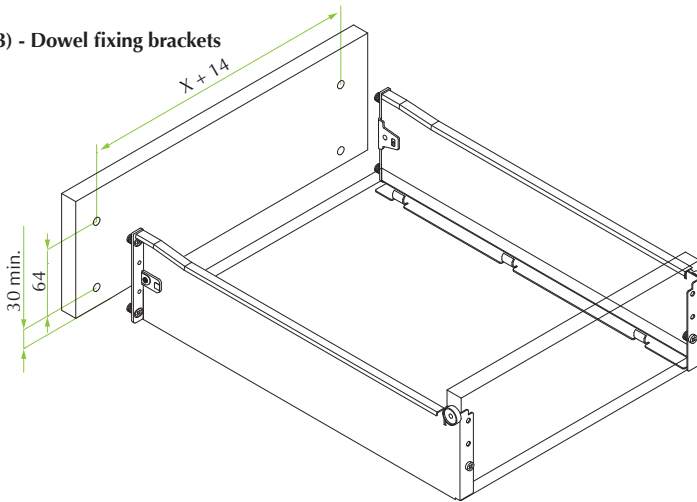

DRAWER 881 - H150

Machine version (MAC 3) - Dowel fixing brackets

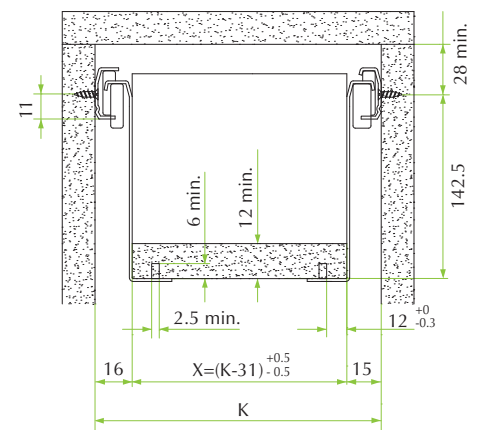
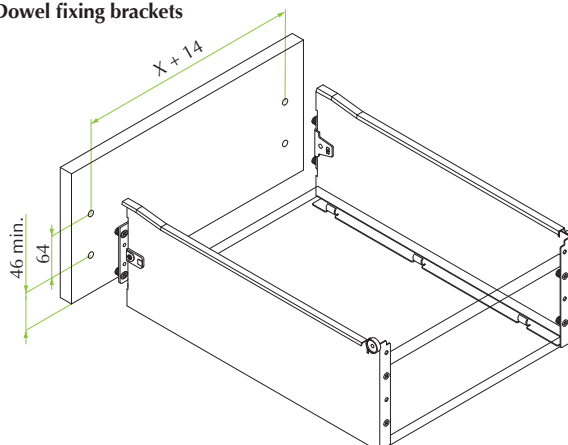

Back panels & back fixing



Back fixing and back panels

Benefits for the industry

- For wooden back panels, the drawer has an integrated bracket
- Identical width for wooden bottom and back panel
- Metal back panels available for all heights and 7 standard width in 3 variants for cabinet panel thickness (15, 16, 18)
- Elegant standard heights (85-117) and practical high panel (150-180) with multiple railing positions
- Click-hold feature for ease of assembly

Benefits for the consumer

- Smooth epoxy finished surface for hygiene and ease of cleaning
- Perfect colour match on metal backs with drawer finish
- Ease of assembly with click-hold feature for flat-pack furniture



Low metal back panel



High metal back panel



Railing plastic back fixing for metal back panel included in the packaging

LOW METAL BACK PANEL for 16mm bottom panel

For drawer H85

Code	Description	Packing
58.0KF6.0*.23°00	Low metal back panel for 300 cabinet width	20 per box
58.0KF6.0*.33°00	Low metal back panel for 400 cabinet width	20 per box
58.0KF6.0*.38°00	Low metal back panel for 450 cabinet width	20 per box
58.0KF6.0*.43°00	Low metal back panel for 500 cabinet width	20 per box
58.0KF6.0*.53°00	Low metal back panel for 600 cabinet width	20 per box
58.0KF6.0*.73°00	Low metal back panel for 800 cabinet width	20 per box
58.0KF6.0*.83°00	Low metal back panel for 900 cabinet width	20 per box

* colour codes: 1 = White Ral 9010 / 6 = Grey Ral 7004 / 8 = Silver Ral 9006.

° cabinet panel thickness: 2 = for 18mm / 6 = for 16mm / 8 = for 15mm.

For drawer H117

Code	Description	Packing
58.0KF7.0*.23°00	Low metal back panel for 300 cabinet width	20 per box
58.0KF7.0*.33°00	Low metal back panel for 400 cabinet width	20 per box
58.0KF7.0*.38°00	Low metal back panel for 450 cabinet width	20 per box
58.0KF7.0*.43°00	Low metal back panel for 500 cabinet width	20 per box
58.0KF7.0*.53°00	Low metal back panel for 600 cabinet width	20 per box
58.0KF7.0*.73°00	Low metal back panel for 800 cabinet width	20 per box
58.0KF7.0*.83°00	Low metal back panel for 900 cabinet width	20 per box

* colour codes: 1 = White Ral 9010 / 6 = Grey Ral 7004 / 8 = Silver Ral 9006.

° cabinet panel thickness: 2 = for 18mm / 6 = for 16mm / 8 = for 15mm.

HIGH METAL BACK PANEL for 16mm bottom panel

For drawer H85

Code	Description	Packing
58.AKF6.0*.23°00	High metal back panel for 300 cabinet width	10 per box
58.AKF6.0*.33°00	High metal back panel for 400 cabinet width	10 per box
58.AKF6.0*.38°00	High metal back panel for 450 cabinet width	10 per box
58.AKF6.0*.43°00	High metal back panel for 500 cabinet width	10 per box
58.AKF6.0*.53°00	High metal back panel for 600 cabinet width	10 per box
58.AKF6.0*.73°00	High metal back panel for 800 cabinet width	10 per box
58.AKF6.0*.83°00	High metal back panel for 900 cabinet width	10 per box

* colour codes: 1 = White Ral 9010 / 6 = Grey Ral 7004 / 8 = Silver Ral 9006.

° cabinet panel thickness: 2 = for 18mm / 6 = for 16mm / 8 = for 15mm.

Railing plastic back fixing included in the packaging.

For drawer H117

Code	Description	Packing
58.AKF7.0*.23°00	High metal back panel for 300 cabinet width	10 per box
58.AKF7.0*.33°00	High metal back panel for 400 cabinet width	10 per box
58.AKF7.0*.38°00	High metal back panel for 450 cabinet width	10 per box
58.AKF7.0*.43°00	High metal back panel for 500 cabinet width	10 per box
58.AKF7.0*.53°00	High metal back panel for 600 cabinet width	10 per box
58.AKF7.0*.73°00	High metal back panel for 800 cabinet width	10 per box
58.AKF7.0*.83°00	High metal back panel for 900 cabinet width	10 per box

* colour codes: 1 = White Ral 9010 / 6 = Grey Ral 7004 / 8 = Silver Ral 9006.

° cabinet panel thickness: 2 = for 18mm / 6 = for 16mm / 8 = for 15mm.

Railing plastic back fixing included in the packaging.

METAL BACK PANEL

Low metal back panel

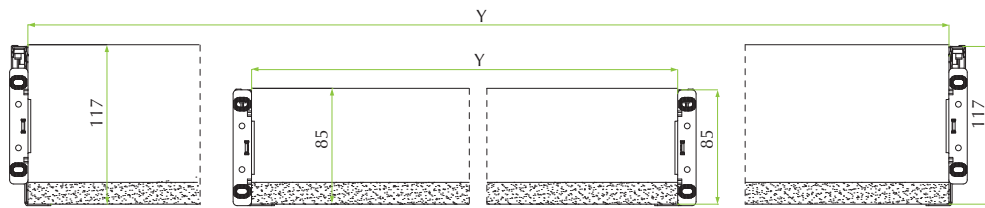

High metal back panel

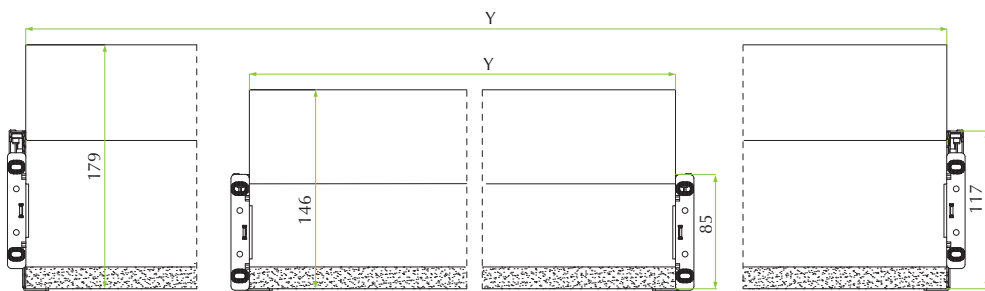

WOODEN BACK PANEL

Front view

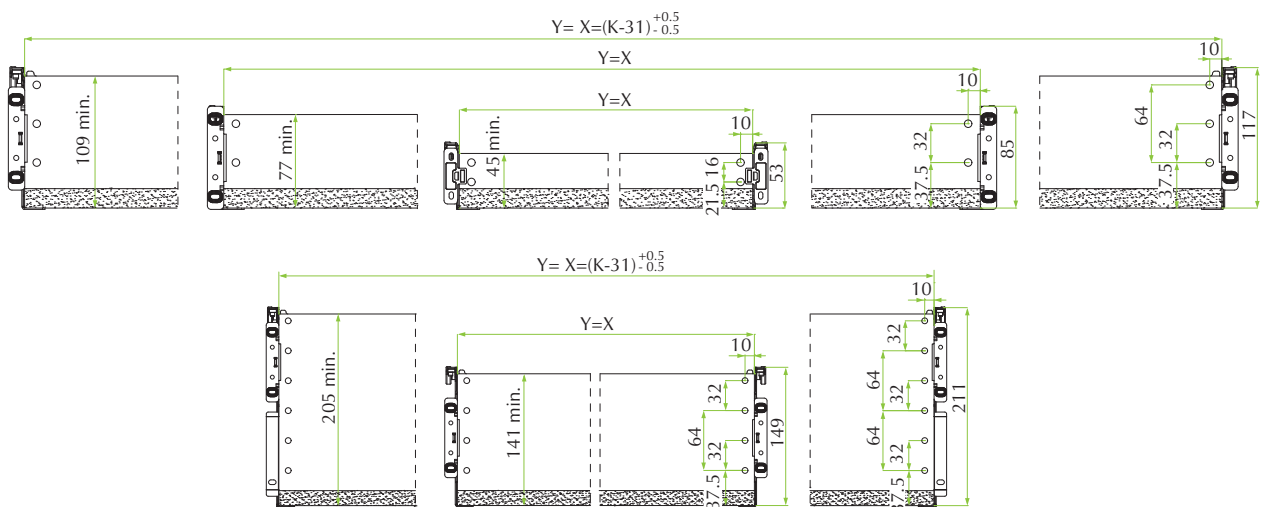

Back view

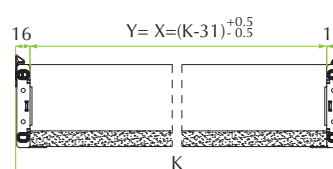

Y = BACK WIDTH
X = BOTTOM WIDTH
K = INTERNAL CABINET WIDTH

Round railing & transversal tubes



Round railing & separation tubes

Benefits for the industry

- Large range of dimensions from 250 to 550 mm depth
- Brackets for wooden backs and metal backs available
- Easy one-step fixing and screw-on for front attachment available as alternatives
- Economical round railing section for kitchen and bathroom applications
- Rectangular section for heavy duty applications

Benefits for the consumer

- Improved containment of storage in high drawer applications (pan drawers)
- Space management from back to front, thanks to separator tubes
- Lasting quality thanks to solid built and optimised materials

ROUND EASYFIX RAILING

Code	Description	Packing
58.0TLA.0*.250.00	Round EasyFix railing for 250 deep drawer	100 per box
58.0TLA.0*.270.00	Round EasyFix railing for 250 deep drawer	100 per box
58.0TLA.0*.350.00	Round EasyFix railing for 350 deep drawer	100 per box
58.0TLA.0*.400.00	Round EasyFix railing for 400 deep drawer	100 per box
58.0TLA.0*.450.00	Round EasyFix railing for 450 deep drawer	100 per box
58.0TLA.0*.500.00	Round EasyFix railing for 500 deep drawer	100 per box
58.0TLA.0*.550.00	Round EasyFix railing for 550 deep drawer	100 per box

* colour codes: 1 = White Ral 9010 / 6 = Grey Ral 7004 / 8 = Silver Ral 9006.

ROUND SCREW-ON RAILING

Code	Description	Packing
58.0TLB.0*.250.00	Round Screw-On railing for 250 deep drawer	100 per box
58.0TLB.0*.270.00	Round Screw-On railing for 270 deep drawer	100 per box
58.0TLB.0*.350.00	Round Screw-On railing for 350 deep drawer	100 per box
58.0TLB.0*.400.00	Round Screw-On railing for 400 deep drawer	100 per box
58.0TLB.0*.450.00	Round Screw-On railing for 450 deep drawer	100 per box
58.0TLB.0*.500.00	Round Screw-On railing for 500 deep drawer	100 per box
58.0TLB.0*.550.00	Round Screw-On railing for 550 deep drawer	100 per box

* colour codes: 1 = White Ral 9010 / 6 = Grey Ral 7004 / 8 = Silver Ral 9006.

Front attachments



EasyFix railing



Screw-on railing

Back fixing



For metal back panel
(included in the high metal
back panel packaging)



For wooden back panel

Code	Description	Packing
58.03AP.05.00000	Railing back fixing for wooden back panel	200 per box

Selftapping screws included.

ROUND TRANSVERSAL TUBE

Code	Description	Packing
58.0TTC.0*.02330	Round transversal tube for 300 cabinet width	100 per box
58.0TTC.0*.03330	Round transversal tube for 400 cabinet width	100 per box
58.0TTC.0*.03830	Round transversal tube for 450 cabinet width	100 per box
58.0TTC.0*.04330	Round transversal tube for 500 cabinet width	100 per box
58.0TTC.0*.05330	Round transversal tube for 600 cabinet width	100 per box
58.0TTC.0*.07330	Round transversal tube for 800 cabinet width	100 per box
58.0TTC.0*.08330	Round transversal tube for 900 cabinet width	100 per box

* colour codes: 1 = white Ral 9010 / 6 = grey Ral 7004 / 8 = silver Ral 9006.
T shape transversal tube connector not included, to be ordered separately.

Code	Description	Packing
58.0TLC.0*.00000	T shaped transversal tube connector	200 per box

* colour codes: 1 = White Ral 9010 / 6 = Grey Ral 7042.



T tube connector

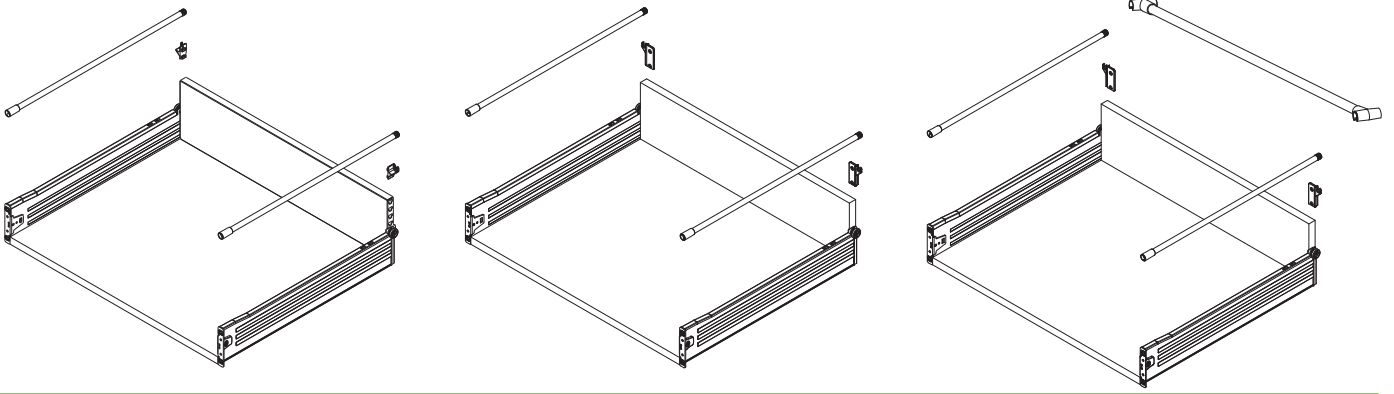

EasyFix railing

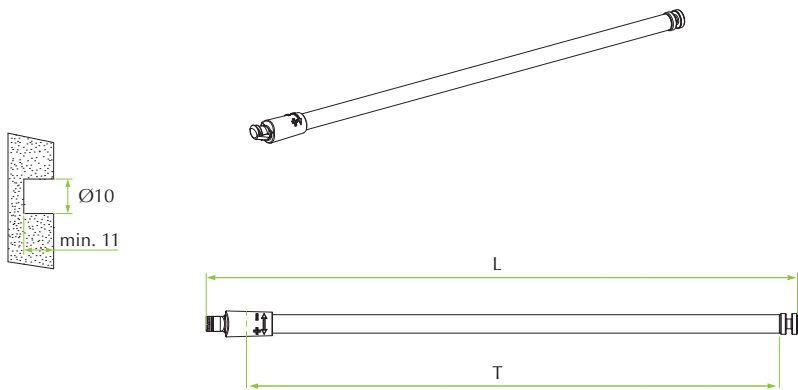

Drawer depth	L	T
250	264	238
270	284	258
350	364	338
400	414	388
450	464	438
500	514	488
550	564	538

Screw-on railing

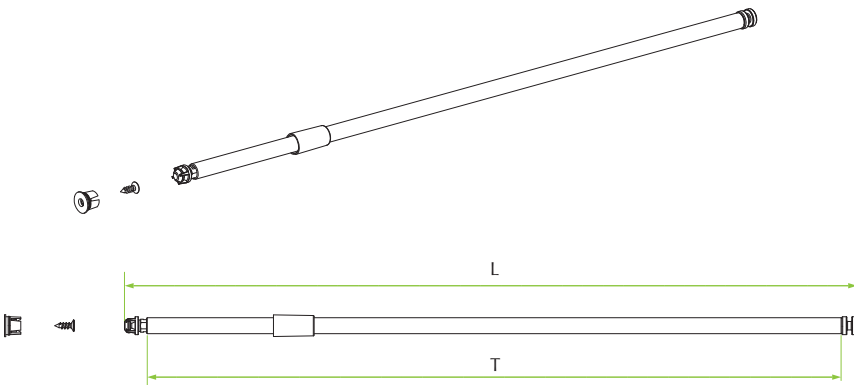

Drawer depth	L	T
250	250	227.5
270	270	247.5
350	350	327.5
400	400	377.5
450	450	427.5
500	500	477.5
550	550	527.5

Transversal tube

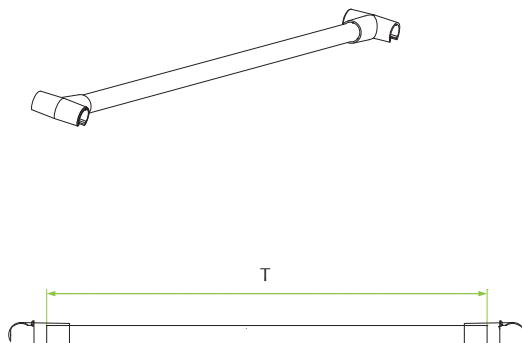

Cabinet width	Cabinet panel thickness	T
300	15/16/18	233
400	15/16/18	333
450	15/16/18	383
500	15/16/18	433
600	15/16/18	533
700	15/16/18	633
800	15/16/18	733
900	15/16/18	833

Square railing & accessories

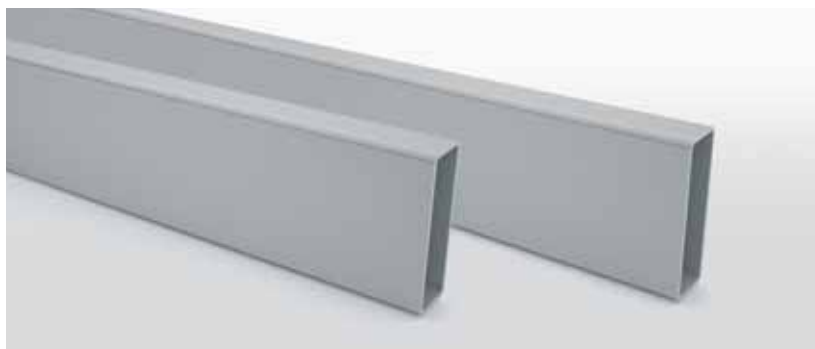

Square railing & accessories

Benefits for the industry

- Large range of dimensions from 250 to 550 mm depth
- Solution for wooden backs
- Rectangular section for heavy duty applications

Benefits for the consumer

- Improved containment of storage in high drawer applications (pan drawers)
- Space management from back to front, thanks to separator tubes
- Lasting quality thanks to solid built and optimised materials

SQUARE RAILING

Code	Description	Packing
34.0TLO.0*.246.00	Square railing for 250 deep drawer	100 per box
34.0TLO.0*.266.00	Square railing for 270 deep drawer	100 per box
34.0TLO.0*.346.00	Square railing for 350 deep drawer	100 per box
34.0TLO.0*.396.00	Square railing for 400 deep drawer	100 per box
34.0TLO.0*.446.00	Square railing for 450 deep drawer	100 per box
34.0TLO.0*.496.00	Square railing for 500 deep drawer	100 per box
34.0TLO.0*.546.00	Square railing for 550 deep drawer	100 per box

* colour codes: 1 = White Ral 9010 / 6 = Grey Ral 7004 / 8 = Silver Ral 9006.

SQUARE TRANSVERSAL TUBE

Code	Description	Packing
34.0TTO.0*.231.00	Square transversal tube for 300 cabinet width	100 per box
34.0TTO.0*.331.00	Square transversal tube for 400 cabinet width	100 per box
34.0TTO.0*.381.00	Square transversal tube for 450 cabinet width	100 per box
34.0TTO.0*.431.00	Square transversal tube for 500 cabinet width	100 per box
34.0TTO.0*.481.00	Square transversal tube for 550 cabinet width	100 per box
34.0TTO.0*.531.00	Square transversal tube for 600 cabinet width	100 per box
34.0TTO.0*.731.00	Square transversal tube for 800 cabinet width	100 per box
34.0TTO.0*.831.00	Square transversal tube for 900 cabinet width	100 per box

* colour codes: 1 = White Ral 9010 / 6 = Grey Ral 7004 / 8 = Silver Ral 9006.

ACCESSORIES

Code	Description	Packing
2H.0172.12.1*.000	Front connector	100 per box
2H.0172.12.2*.000	Lateral connector	50 per box
2H.0172.12.0*.000	Back connector	100 per box
2H.0172.12.5*.000	Back stop	500 per box

* colour codes: 1 = White Ral 9010 / 8 = Grey Ral 7042.

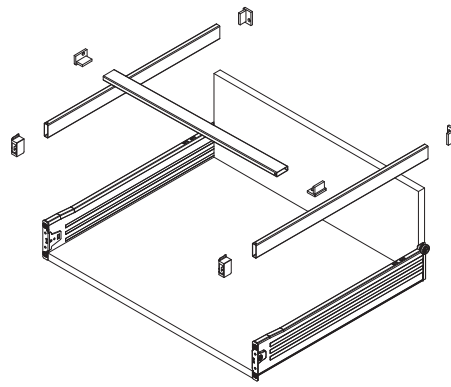
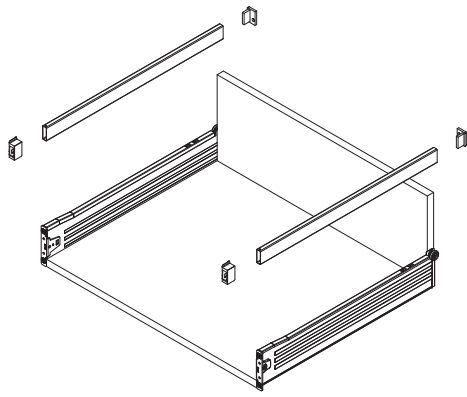

Square railing & transversal tube

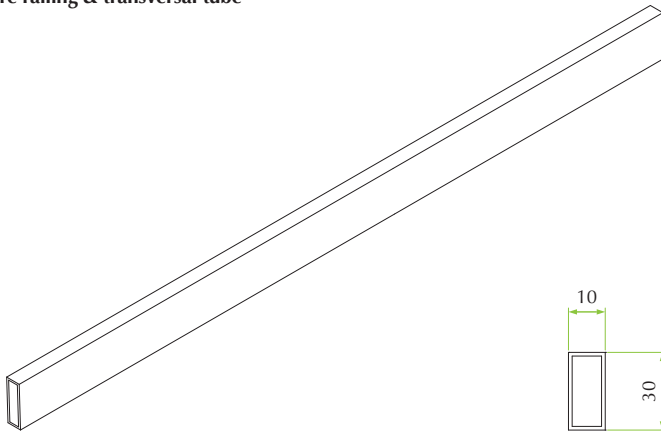

Square railing tube

Drawer depth	T
250	245
270	265
350	345
400	395
450	445
500	495
550	545

Square transversal tube

Cabinet base	T
300	229
400	329
450	379
500	429
550	479
600	529
800	729
900	829

Accessories



Front connector



Lateral connector



Back connector



Back stop

Internal drawer

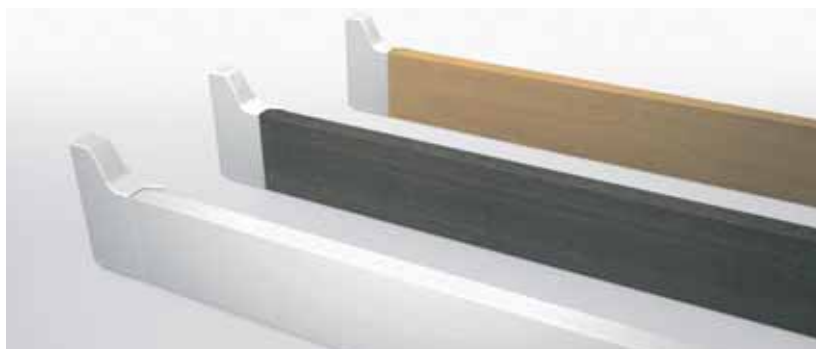

4-sided internal drawer

Benefits for the industry

- Standardisation of cabinets with doors only and no need for multiple handles
- Retrofittable drawer solutions as internal application behind standard doors
- Front bracket for simple production

Benefits for the consumer

- Free positioning of the drawer, as there is no pattern imposed by drawer fronts
- Cost effective retrofit solution
- Ease of cleaning of large doors, instead of multiple drawer fronts
- Regular design of fronts in kitchen, especially of small size

Code

58.0200.01.00R00

58.0200.01.00L00

Description

Right front bracket for internal drawer H85

Left front bracket for internal drawer H85

Packing

250 per box

250 per box

* colour codes: 1 = White Ral 9010 / 8 = Grey Ral 7042.



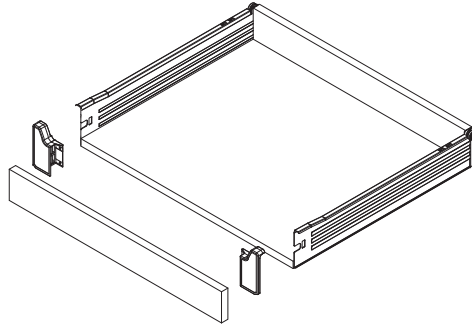

Uniset internal drawer H85:

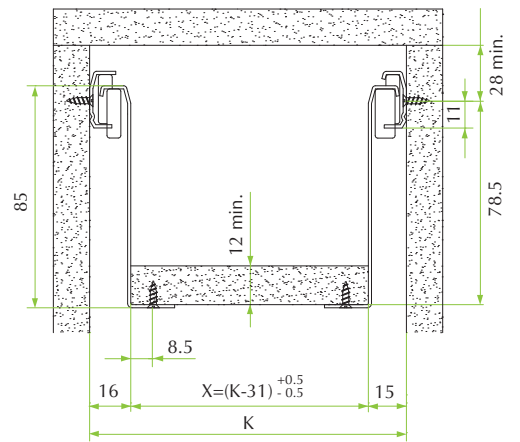
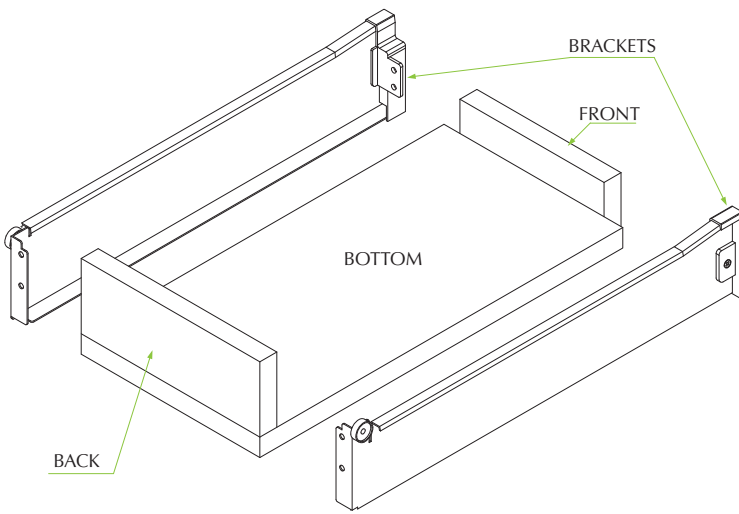

Front & back drilling pattern

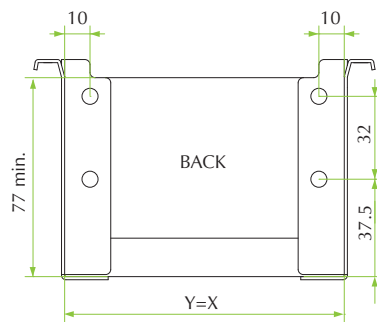
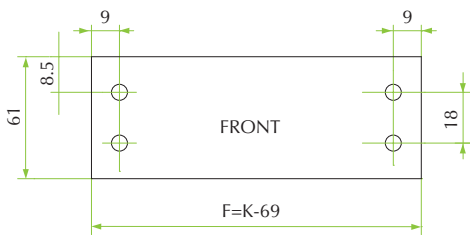

F = FRONT WIDTH
X = BOTTOM WIDTH
Y = BACK WIDTH
K = INTERNAL CABINET WIDTH

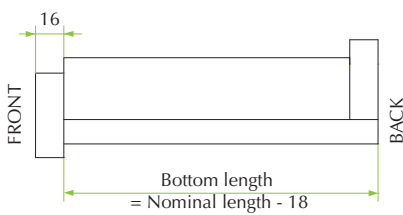

Tetrix cutlery tray for Uniset drawer



Quality moulded cutlery tray for perfect storage and ease of cleaning

Benefits for the industry

- New production technology for competitiveness
- Perfect match in colour with Uniset range and accessories
- Universal product for drawer
- Stackable for packing and transport
- Easy to sell retrofit solution

Benefits for the consumer

- Perfect finish and quality features of moulded product
- Many standard dimensions
- Easy to clean, easy to remove, easy to position

Code	Description	Packing
59.T001.S6.280.U000	Universal Tetrix cutlery tray 300/350	25 pieces
59.T001.S6.400.U000	Universal Tetrix cutlery tray 400/450	25 pieces
59.T001.S6.500.U000	Universal Tetrix cutlery tray 500/550	25 pieces
59.T001.S6.550.U000	Universal Tetrix cutlery tray 600	25 pieces

*Made in PP standard finish Silver Champagne RAL 7030.
Industrial packing of 25 pieces per box.*

On request with minimum order quantity:

- white finish RAL 9003
- cutlery tray cut to size on the drawer dimensions.

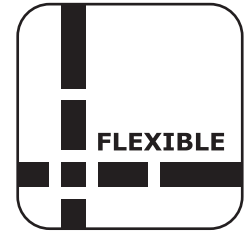

Cutlery tray dimensions

UNIVERSAL VERSION

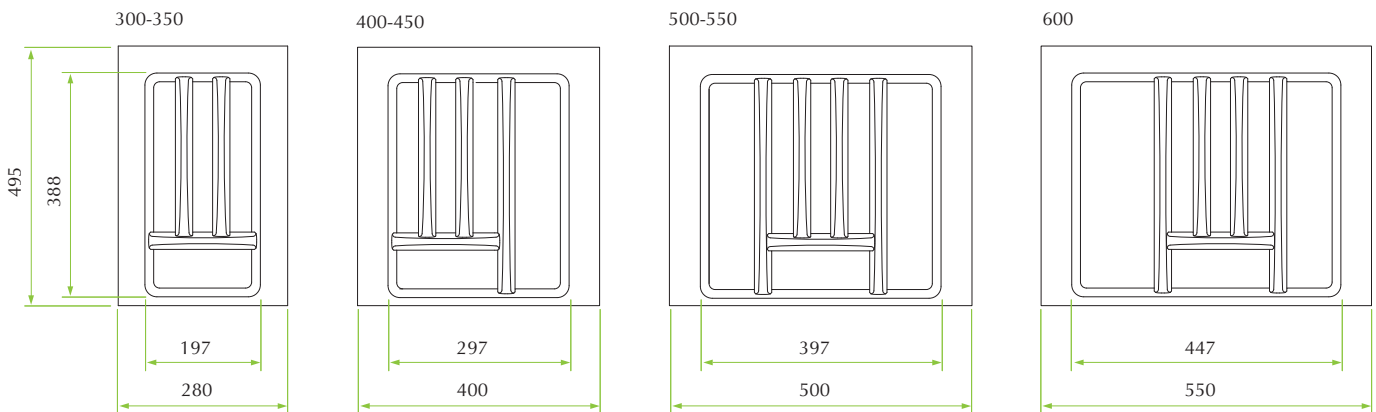

CUT TO SIZE VERSION

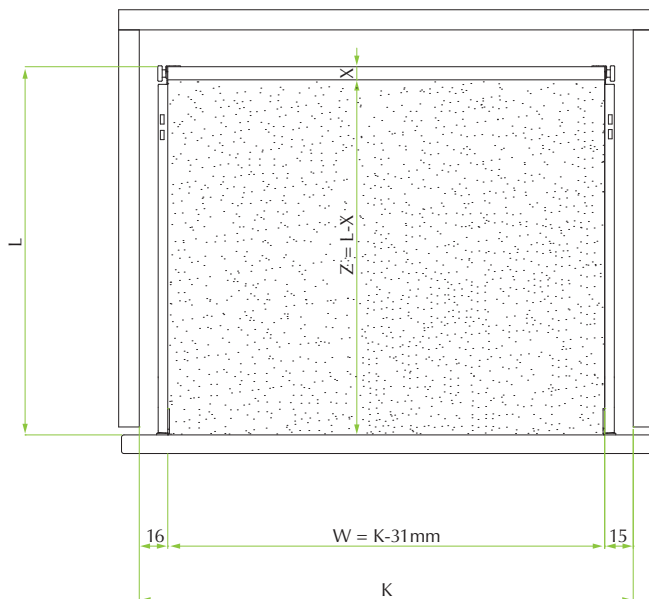

- K** = INTERNAL CABINET WIDTH
- W** = INTERNAL DRAWER WIDTH FOR TETRIX CUTLERY TRAY CUT TO SIZE
- L** = DRAWER NOMINAL LENGTH
- Z** = INTERNAL DRAWER LENGTH FOR TETRIX CUTLERY TRAY CUT TO SIZE
- X** = BACK PANEL THICKNESS (FOR UNISET METAL BACK APPLICATION X=17mm)

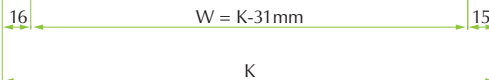

SlowMotion Zeta ANYWAY



Technical specifications:

- Solution for Uniset metal single wall drawer system
- Silent drawer closing movement and drawer pull close guaranteed
- Retrofit solution for all height and depth drawer
- Self closing with damping effect to provide high-end feel to steel drawer
- Simple screw on assembly on cabinet and drawer

PACK IN KIT



SLOWMOTION ZETA DAMPER



SLOWMOTION ZETA BRACKETS



Code

59.072D.**.Z0X._0C1

59.0720.01.Z0X._020

59.072D.**.Z00.0020

**Colour of plastic brackets:

**= 01 White RAL 9010

**= 06 Grey RAL 7042

_ Damper Fixing:

_ = 0 selftapping screws fixing 2x (Ø4x20 mm)

_ = E euro screws fixing 2x (Ø6.3x20 mm)

Description

Kit SlowMotion Zeta ANYWAY for Uniset drawer

SlowMotion Zeta ANYWAY Damper – White RAL 9010

Uniset drawer fixing bracket

Packing

200 kits per box

200 pieces per box

200 pieces per box

Kit composed by:

1 Damper

1 Fixing bracket

1 Drilling template

Fixing screws

Application:

Number of SlowMotion Zeta ANYWAY recommended

Drawer	WIDTH					
	300 350	400 450	500	600	700	800 900
250	1	1	1	1	2	2
270	1	1	1	1	2	2
350	1	1	1	1	2	2
400	1	1	1	1	2	2
450	1	1	1	2	2	2
500	1	1	2	2	2	2
550	1	1	2	2	2	2

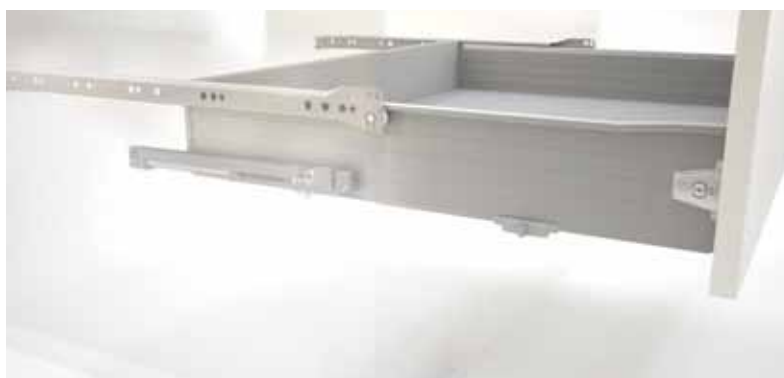



Assembly:

SlowMotion Zeta damper on the cabinet

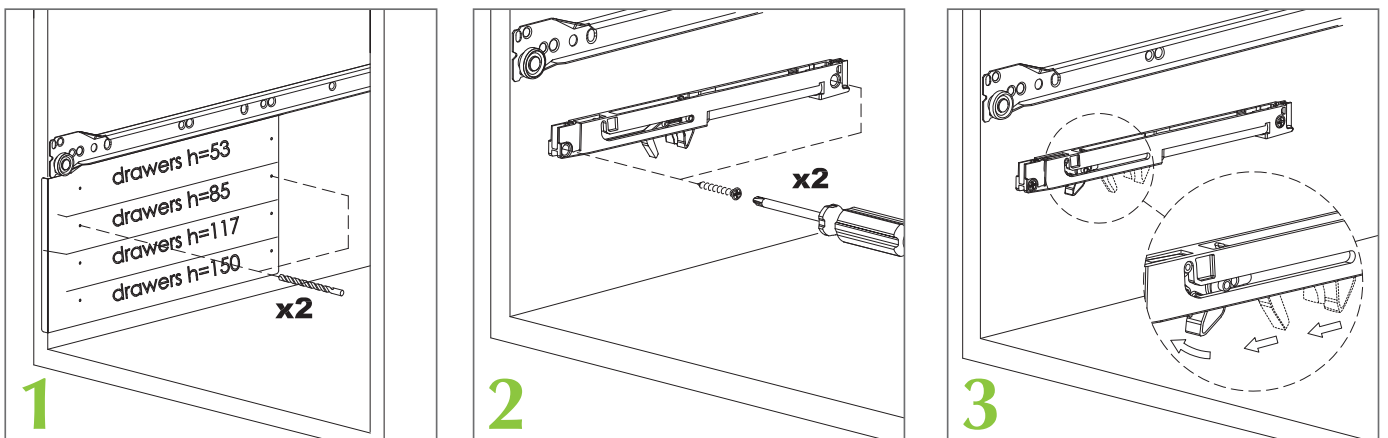

SlowMotion Zeta brackets on the drawer

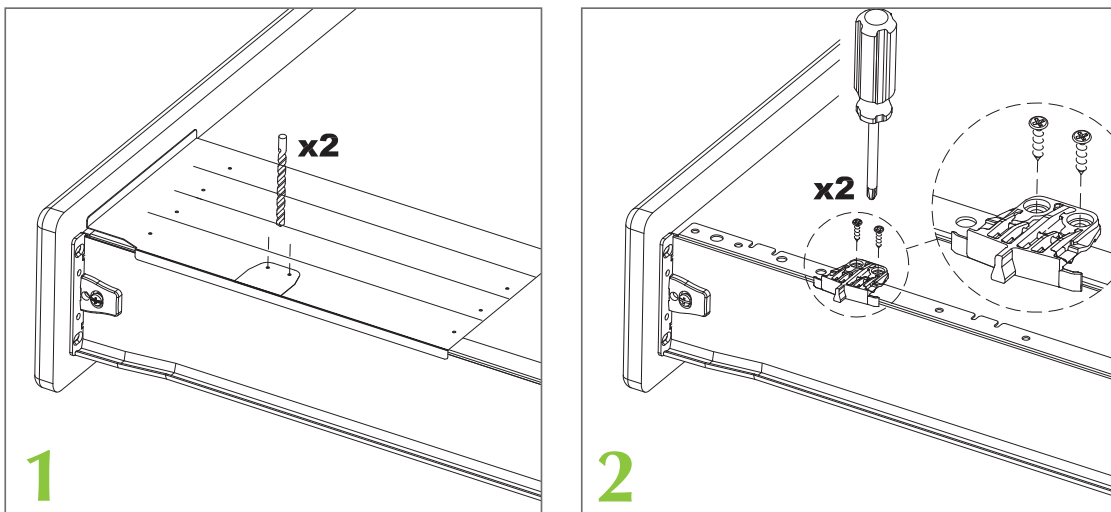



MAC 3 AV automatic assembly machine for Uniset drawers

- Adjustable to mount 681/781/881 Uniset drawers with steel sides
- Practical system of locating stops for the drawer components positioning in the machine
- Drawers mounting process by pressure bars controlled by pneumatic cylinders
- Finished drawer assembly with constant accuracy
- Simple operator's control required

Code	Description	Packing
A8.0MAC.30.00000	MAC 3 AV automatic assembly Machine for Uniset drawers	1 piece

Please request the separate documentation and the instructions for use of this machine.



Front drilling and insertion machine

- For front fix with 10mm pegs equipped with insertion RAM
- Easy positioning of the front with removable stops left and right
- Insertion RAM to hold the front fixing
- To be positioned on a worktop

Code	Description	Packing
A5.0DEL.IB.4800000	Drilling and insertion machine	1 piece
AH.01G7.20.75.000	RAM	1 piece



RAM

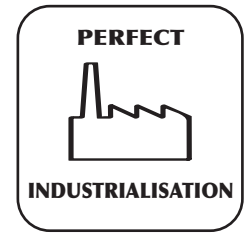
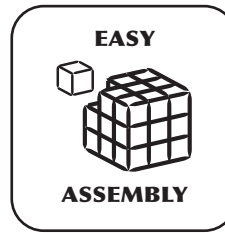

MAC 1 MV manual assembly machine for Uniset drawers

- Adjustable to mount 651/751/851 Uniset drawers with steel sides
- Practical system of locating stops for the drawer components positioning in the machine
- Manual operation: the machine keeps the drawer components in position to be fixed by the operator
- To be positioned on a worktop

Code	Description	Packing
A4.0MAC.10.00000	MAC 1 MV manual assembly Machine for Uniset drawers	1 piece



Mounting sequence

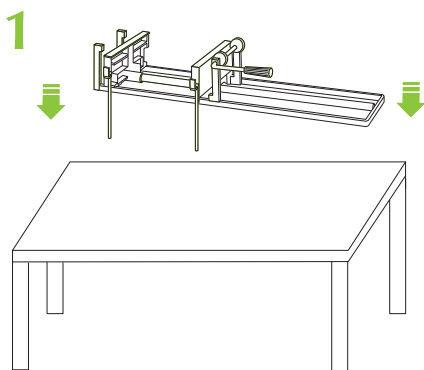

Position the machine on a work bench or a table

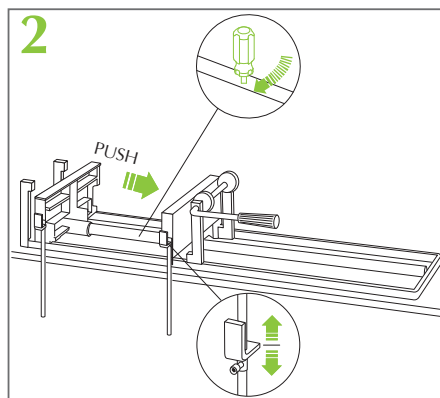

Adjust the clamps according to the height of the back panel.
Adjust the position of the right side of the machine according to the dimension of the drawer bottom by using the lever which is situated on the right of the moving part

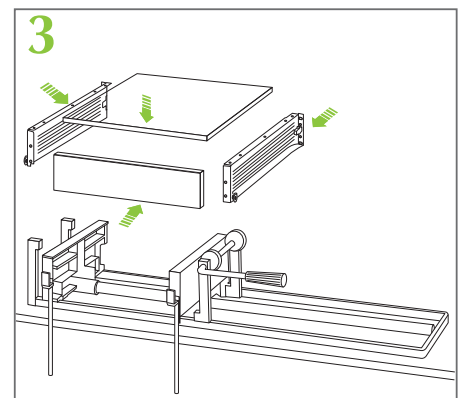

Position the rear panel, the drawers sides and the bottom, as for illustration

Accessories:



Manual RAM



Drilling jig

Code	Description	Packing
AH.01G7.20.75.100	Manual RAM	10 piece
A0.P200.00.000	Drilling jig	1 piece

Instructions for use

Round railing for metal back panel - assembly sequence

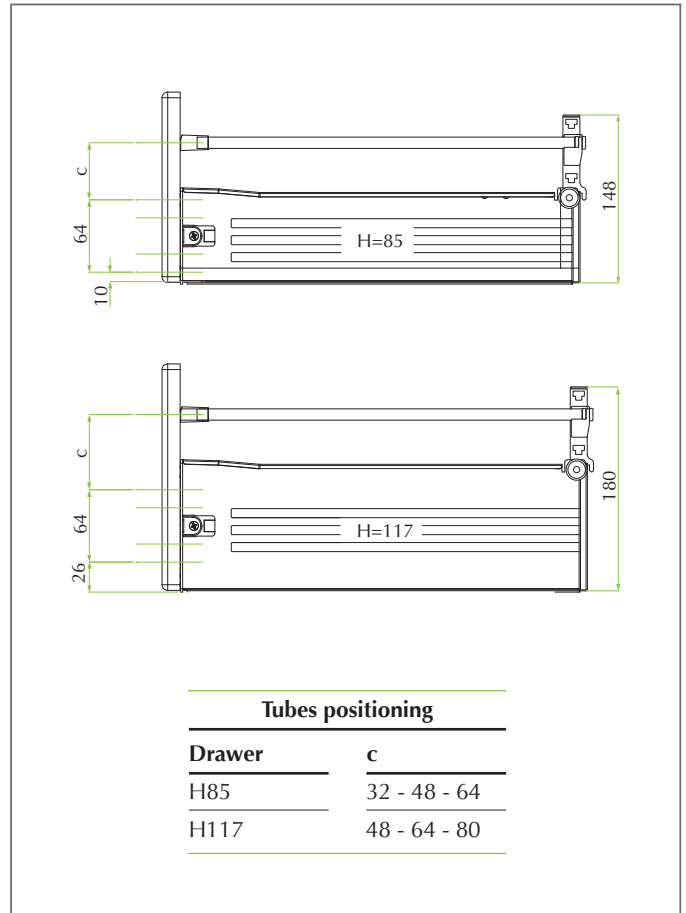
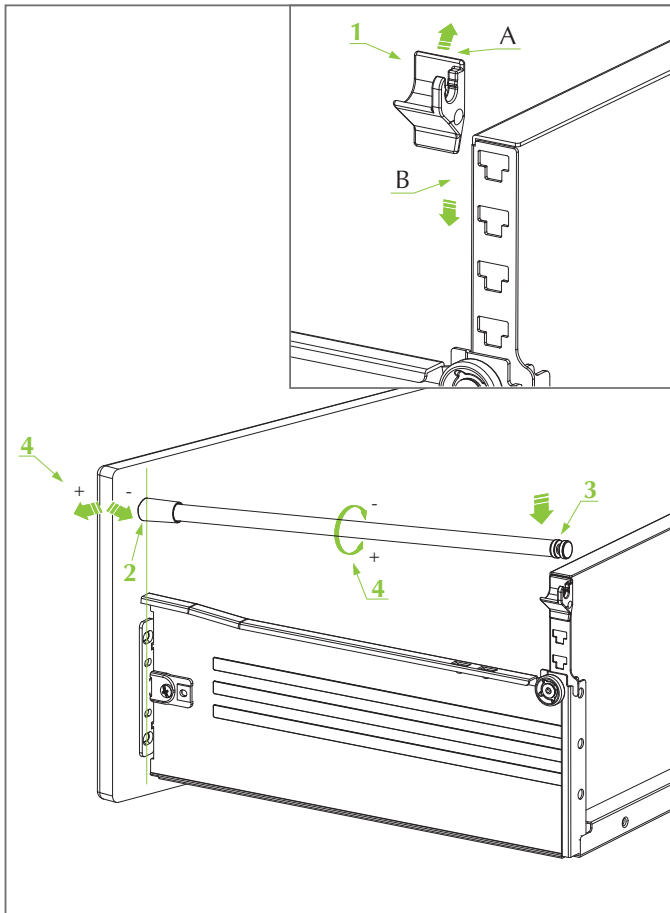

Round railing for wooden back panel - assembly sequence

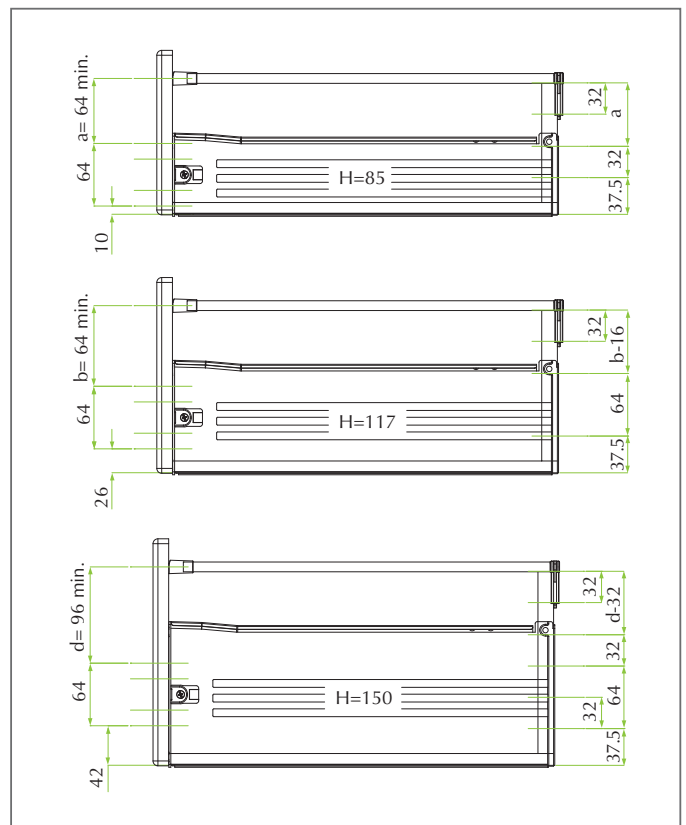
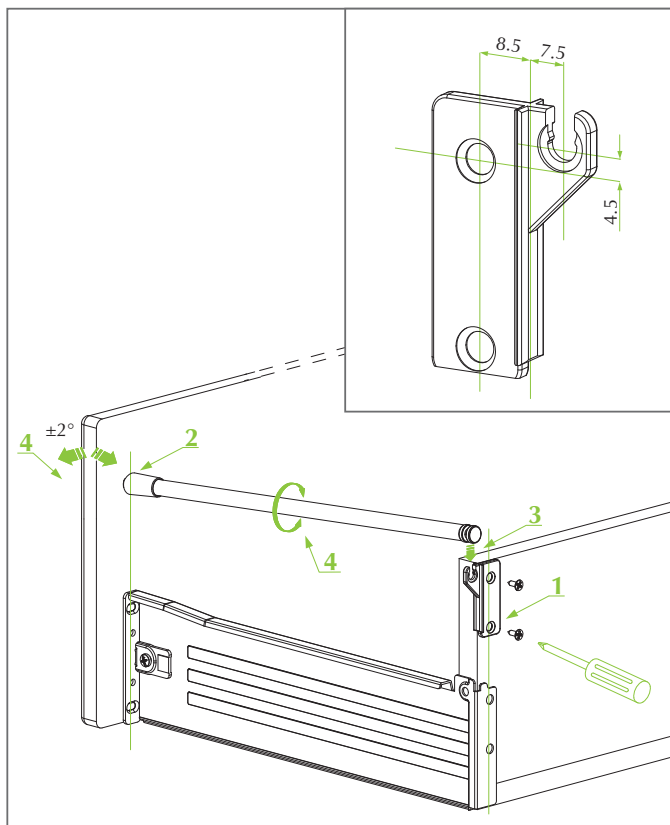

Instructions for use

Pan drawer with square railing - assembly sequence

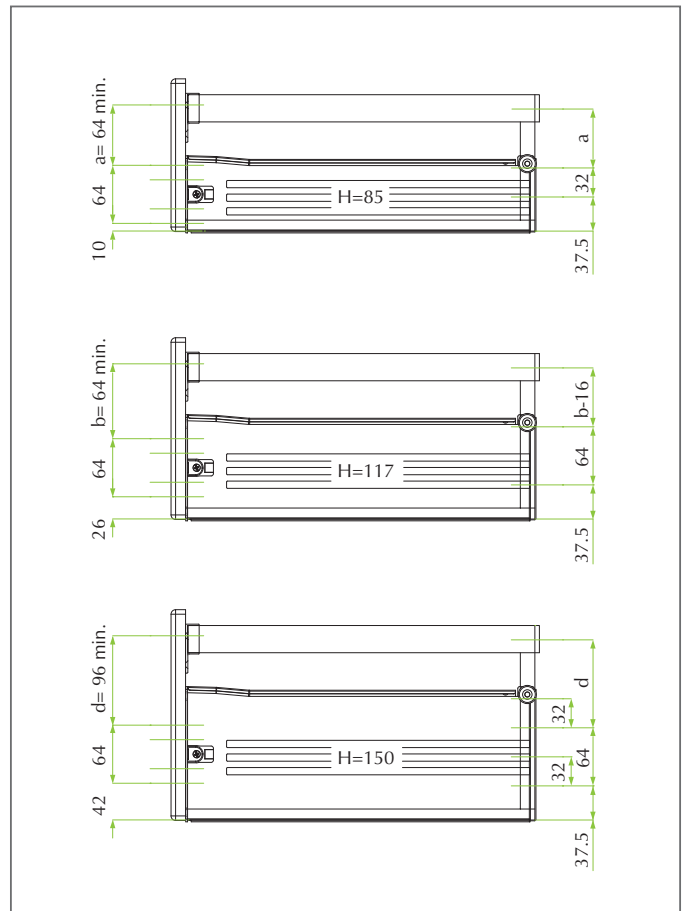
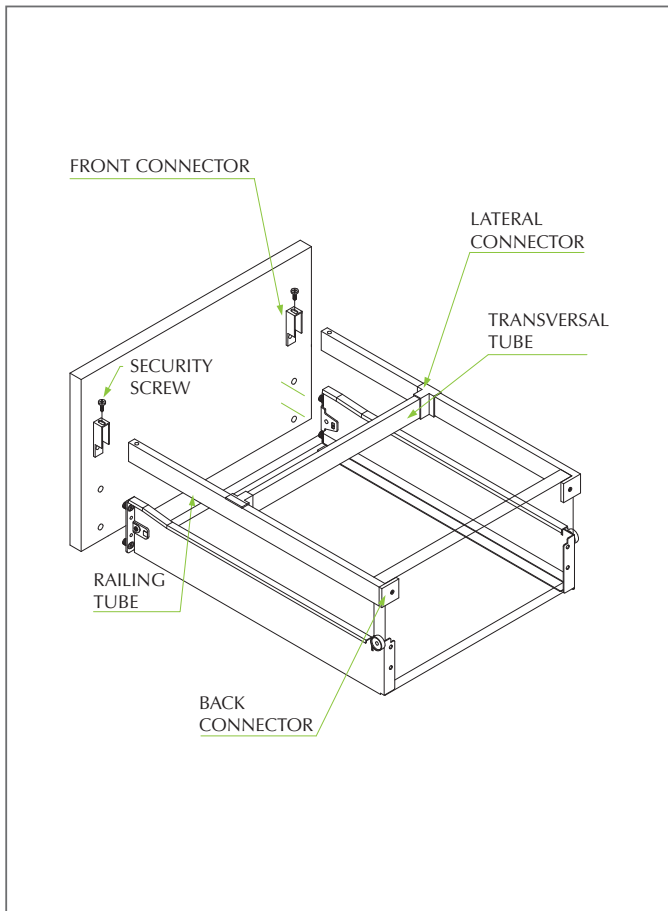

Euro screw

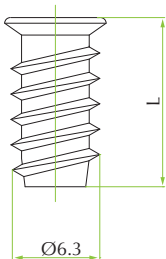

Code

1A.0751.01280CF

1A.0751.01180CF

Description

Euro screw L=12

Euro screw L=10

Packing

5.000 pieces per box

5.000 pieces per box

Selftapping screw

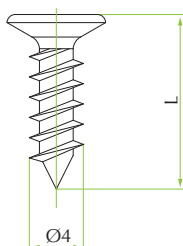

Code

1A.0350.34.150CF

1A.0350.34.250CF

Description

Selftapping screw L=12

Selftapping screw L=15

Packing

20.000 pieces per box

15.000 pieces per box